

22/6/14

Rigid bodies

are the bodies that they do not deform under the action of applied forces. Rigid body is an object with a mass that holds a rigid shape.

Deformable bodies

Any body that changes its shape and volume while being acted upon by any kind of external force.

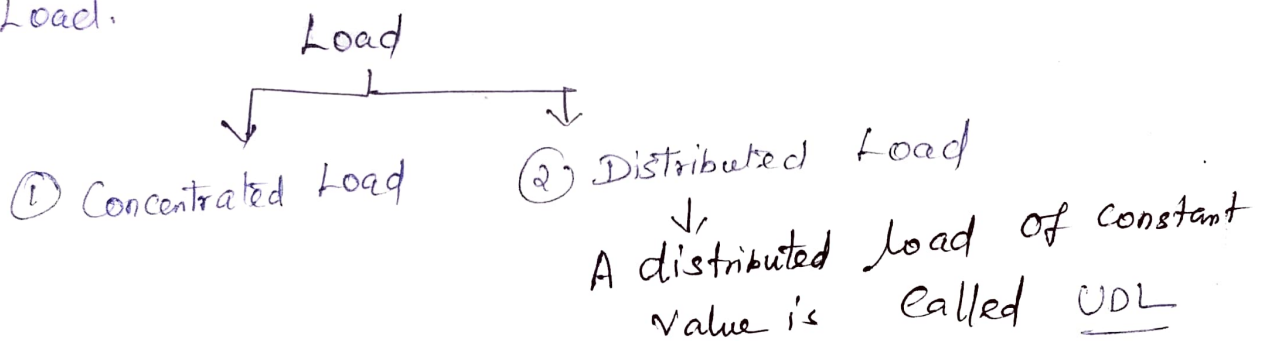
Strength

The ability of a material to support (or) carry an load.

Strength of materials deals with the strength or the load carrying capacity of various members such as beams and columns.

Load The force acting on a body is termed as

Load.



Tensile force is pulling force  $\rightarrow$  known as tension (or)

tensile force.

Tensile force increase the length and decrease the cross section of the body.

A force tending to push or compress a body is known as compression (or) compressive force which tends to shorten the length.

Axial forces The forces acting on a body along the longitudinal axis are known as direct or axial forces.

Normal forces The forces acting normal to the longitudinal axis of a body are known as transverse (or) normal forces.

Elastic body

A material subjected to external forces is assumed to be perfectly elastic, (ie) the deformations caused to the body totally disappear as soon as the load (or) forces are removed.

# Strength of materials

## Stress and Strain

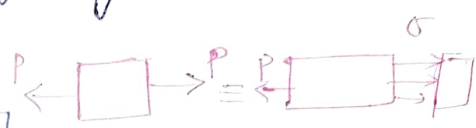
The force of resistance per unit area of body

(Stress  $(\sigma)$  is a unit deformation known as strain)

When a material is subjected to an external force, a resisting force is set up within the component.

The internal force per unit area acting on a material or intensity of the forces distributed over a given section is called the stress at a point.

(It uses original cross section area of the specimen is also known as engineering stress or conventional strain.)



therefore stress  $\sigma = \frac{P}{A}$

P expressed in Newton, and A original area in square meters ( $m^2$ )  $\sigma \rightarrow N/m^2 = \text{Pascal}$ .

- 1 kPa =  $10^3$  Pa =  $10^3$  N/m<sup>2</sup>
  - 1 MPa =  $10^6$  Pa =  $10^6$  N/m<sup>2</sup> = 1 N/mm<sup>2</sup>
  - 1 GPa =  $10^9$  Pa =  $10^9$  N/m<sup>2</sup>
- (2) Strain: It is the ratio of change in dimension of the body to the original dimension. It has no unit. It has no unit is section.

Example A rod 10mm x 10mm cross carrying an axial tensile load 10kN. In this rod the tensile stress is developed given by

$$\sigma_t = \frac{P}{A} = \frac{10 \times 10^3}{10 \times 10} = 100 \text{ N/mm}^2 = 100 \text{ MPa}$$

When a member is subjected to equal opposite axial pulls as shown in fig. the length of the member is increased. The stress induced at any section of the member is called tensile stress.



Tensile stress  $\sigma = \frac{\text{Tensile load}}{\text{Area}}$

$$\sigma = \frac{P}{A}$$

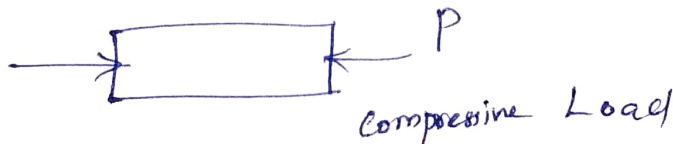
(The ratio of increase in length to the original length is known as tensile strain.)

Tensile strain ( $e$ ) =  $\frac{\text{Increase in length}}{\text{Original length}}$

$$e = \frac{\delta L}{L}$$

Compressive stress  $\sigma_c$ , Compressive strain.

When a member is subjected to equal and opp axial pushes as shown in , the length of the member is shortened. The stress induced at any cross section of the member is called Compressive stress.



Compressive stress  $\sigma = \frac{\text{Compressive Load}}{\text{Area}}$

$$\sigma = \frac{P}{A}$$

length is known as decrease in length to the original  
 known as Comp strain.

Compressive Strain  $e = \frac{\text{Decrease in length}}{\text{Original length}}$

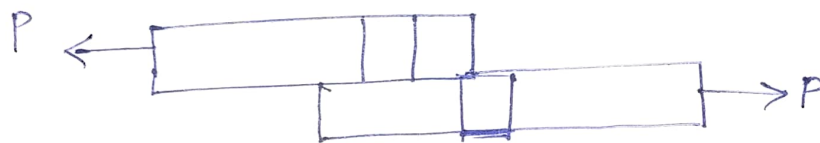
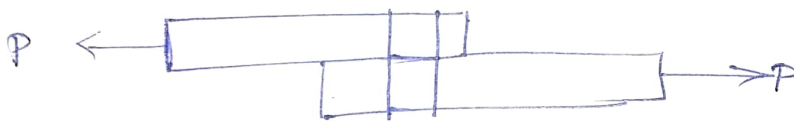
$$e_c = \frac{\Delta L}{L}$$

Note

If  $\sigma > 0$  the stress is tensile.  
 If  $\sigma < 0$  the stress is compressive.

Shear stress & Shear strain

The two equal & opp forces act tangentially on any cross sectional plane of a body tending to slide one part of the body over the part. The stress induced in that section is called shear stress and corresponding strain is known as shear strain.



Volumetric strain

is defined as the ratio of change in volume to the original volume of the body.

Volumetric strain =  $\frac{\text{Change in volume}}{\text{Original volume}}$

$$e_v = \frac{\Delta V}{V}$$

Hook's Law states when a material is loaded, within its elastic limit, the stress is directly proportional to strain (within its elastic limit)

$$\sigma \propto e$$

$$\sigma = Ee$$

$$E = \frac{\sigma}{e}$$

$E$  = Young's modulus or modulus of Elasticity.

Factor of Safety

It is defined as the ratio of ultimate tensile stress to the permissible stress (working stress)

$$\text{Factor of Safety} = \frac{\text{Ultimate stress}}{\text{Permissible stress}}$$

Deformation of a body due to force acting on it

Consider a body subjected to a tensile stress

W.K.T

$$\text{stress } \sigma = \frac{\text{Load}}{\text{Area}} = \frac{P}{A}$$

$$\text{Strain } e = \frac{\text{change in length}}{\text{Original length}} = \frac{\Delta L}{L}$$

From Hook's Law

$$\text{Young's modulus, } E = \frac{\text{stress}}{\text{strain}} = \frac{\sigma}{e}$$

A rod 2m long and 3cm dia is subjected to an axial pull of 10kN. If  $E$  for steel is  $2 \times 10^5 \text{ N/mm}^2$ . Find (a) stress (b) strain (c) Elongation of the rod.

Given

Length of rod = 2m

= 2000mm

dia of rod = 3cm

Axial load = 10kN

$E = 2 \times 10^5 \text{ N/mm}^2$

Stress =  $\frac{P}{A}$

=  $\frac{10 \times 10^3}{\frac{\pi}{4} (d^2)}$  =  $\frac{10 \times 10^3}{\frac{\pi}{4} \times (3 \times 10^{-2})^2}$

=  $\frac{4 \times 10 \times 10^3}{\pi \times (3 \times 10^{-2})^2}$

= ~~42441318.16~~

14147106.05  $\text{N/m}^2$  = 14.14  $\text{N/mm}^2$

Strain  $E = \frac{\sigma}{e}$

$2 \times 10^5 = \frac{14.14}{e} = 7.07 \times 10^{-5}$

Strain  $e = 7.07 \times 10^{-5}$

W.K.T

Strain =  $\frac{\text{Change in length}}{\text{Original length}}$

# Simple Stresses and Strains

Expressions for stresses and strains is derived with the following assumptions:

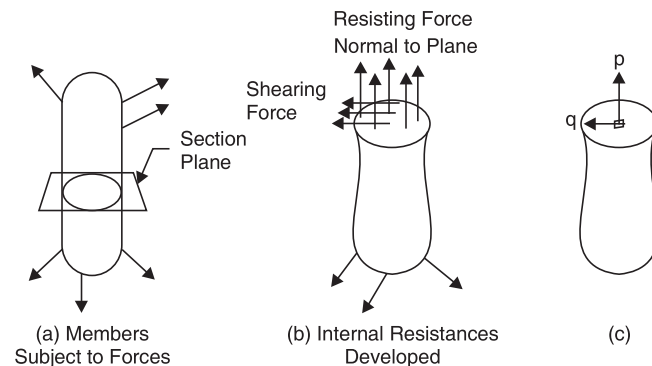
1. For the range of forces applied the material is elastic *i.e.* it can regain its original shape and size, if the applied force is removed.
2. Material is homogeneous *i.e.* every particle of the material possesses identical mechanical properties.
3. Material is isotropic *i.e.* the material possesses identical mechanical property at any point in any direction.

Presenting the typical stress-strain curve for a typical steel, the commonly referred terms like limits of elasticity and proportionality, yield points, ultimate strength and strain hardening are explained.

Linear elastic theory is developed to analyse different types of members subject to axial, shear, thermal and hoop stresses.

## MEANING OF STRESS

When a member is subjected to loads it develops resisting forces. To find the resisting forces developed a section plane may be passed through the member and equilibrium of any one part may be considered. Each part is in equilibrium under the action of applied forces and internal resisting forces. The resisting forces may be conveniently split into normal and parallel to the section plane. The resisting force parallel to the plane is called *shearing resistance*. The intensity of resisting force normal to the sectional plane is called *intensity of Normal Stress* (Ref. Fig.).



**Fig.**

In practice, intensity of stress is called as “stress” only. Mathematically

$$\begin{aligned} \text{Normal Stress} = p &= \lim_{\Delta A \rightarrow 0} \frac{\Delta R}{\Delta A} \\ &= \frac{dR}{dA} \end{aligned} \quad \dots(1)$$

where  $R$  is normal resisting force.

The intensity of resisting force parallel to the sectional plane is called *Shearing Stress* ( $q$ ).

$$\text{Shearing Stress} = q = \lim_{\Delta A \rightarrow 0} \frac{\Delta Q}{\Delta A} = \frac{dQ}{dA} \quad \dots(2)$$





where  $Q$  is Shearing Resistance.

Thus, *stress at any point may be defined as resistance developed per unit area*. From equations (1) and (2), it follows that

$$dR = p dA$$

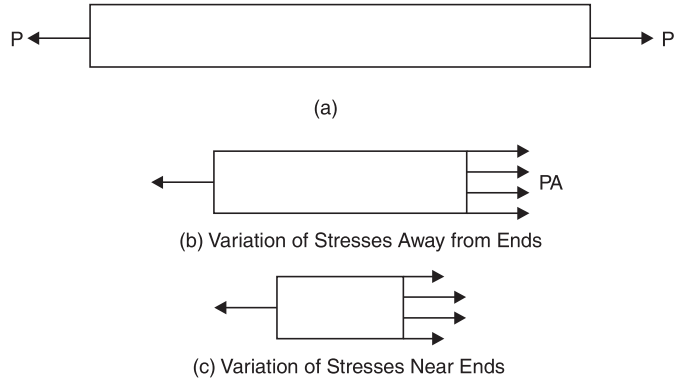
or

$$R = \int p dA \quad \dots(3a)$$

and

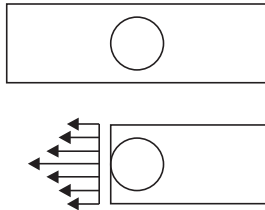
$$Q = \int q dA \quad \dots(3b)$$

At any cross-section, stress developed may or may not be uniform. In a bar of uniform cross-section subject to axial concentrated loads as shown in Fig. 2a, the stress is uniform at a section away from the applied loads (Fig. 2b); but there is variation of stress at the section near the applied loads (Fig. 2c).

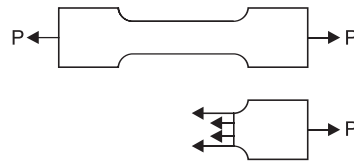


**Fig. 2**

Similarly stress near the hole or at fillets will not be uniform as shown in Figs. 3 and 4. It is very common that at some points in such regions maximum stress will be as high as 2 to 4 times the average stresses.



**Fig. 3.** Stresses in a Plate with a Hole



**Fig. 4**

### UNIT OF STRESS

When Newton is taken as unit of force and millimetre as unit of area, unit of stress will be  $\text{N/mm}^2$ . The other derived units used in practice are  $\text{kN/mm}^2$ ,  $\text{N/m}^2$ ,  $\text{kN/m}^2$  or  $\text{MN/m}^2$ . A stress of one  $\text{N/m}^2$  is known as Pascal and is represented by Pa.

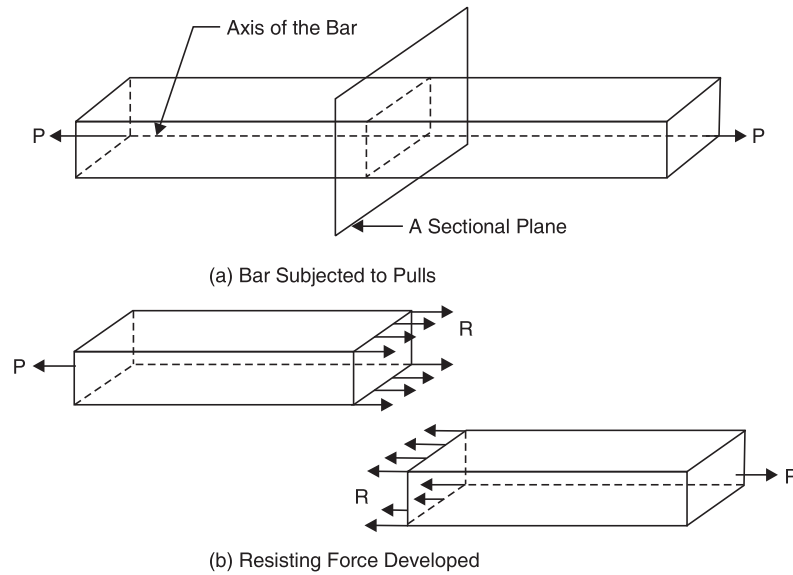
Hence,  $1 \text{ MPa} = 1 \text{ MN/m}^2 = 1 \times 10^6 \text{ N}/(1000 \text{ mm})^2 = 1 \text{ N/mm}^2$ .

Thus one Mega Pascal is equal to  $1 \text{ N/mm}^2$ . In most of the standard codes published unit of stress has been used as Mega Pascal (MPa or  $\text{N/mm}^2$ ).

### AXIAL STRESS

Consider a bar subjected to force  $P$  as shown in Fig. 5. To maintain the equilibrium the end forces applied must be the same, say  $P$ .





**Fig. 5.** Tensile Stresses

The resisting forces acting on a section are shown in Fig. 5b. Now since the stresses are uniform

$$R = \int pdA = p \int dA = pA \quad \dots(4)$$

where  $A$  is the cross-sectional area.

Considering the equilibrium of a cut piece of the bar, we get

$$P = R \quad \dots(5)$$

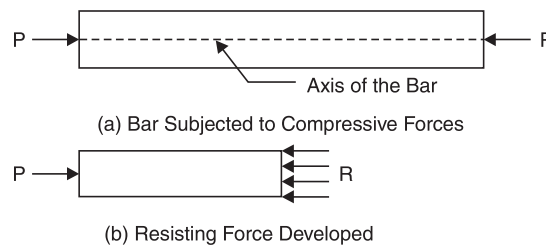
From equations (4) and (5), we get

$$P = pA$$

$$p = P/A$$

Thus, in case of axial load 'P' the stress developed is equal to the load per unit area. Under this type of normal stresses the bar is being extended. Such stress which is causing extension of the bar is called tensile stress.

A bar subjected to two equal forces pushing the bar is shown in Fig. 6. It causes shortening of the bar. Such forces which are causing shortening, are known as compressive forces and corresponding stresses as compressive stresses.



**Fig.6.** Compressive Stresses

Now  $R = \int pdA = p \int dA$  (as stress is assumed uniform)

For equilibrium of the piece of the bar

$$P = R = pA$$

or

$$p = \frac{P}{A} \text{ as in equation 6}$$

Thus, whether it is tensile or compressive, the stress developed in a bar subjected to axial forces, is equal to load per unit area.

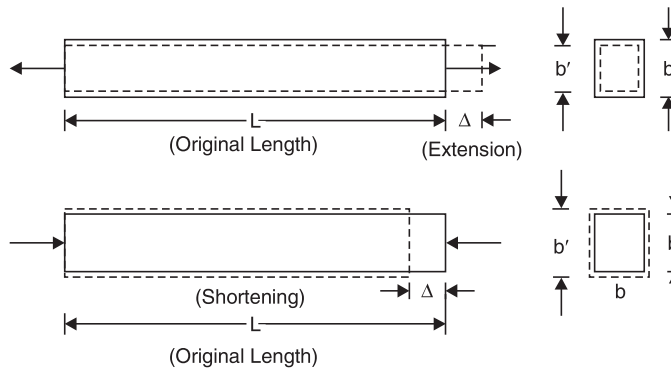


## STRAIN

No material is perfectly rigid. Under the action of forces a rubber undergoes changes in shape and size. This phenomenon is very well known to all since in case of rubber, even for small forces deformations are quite large. Actually all materials including steel, cast iron, brass, concrete, etc. undergo similar deformation when loaded. But the deformations are very small and hence we cannot see them with naked eye. There are instruments like extensometer, electric strain gauges which can measure extension of magnitude 1/100th, 1/1000th of a millimetre. There are machines like universal testing machines in which bars of different materials can be subjected to accurately known forces of magnitude as high as 1000 kN. The studies have shown that the bars extend under tensile force and shorten under compressive forces as shown in Fig. 8.7. *The change in length per unit length is known as linear strain.* Thus,

$$\text{Linear Strain} = \frac{\text{Change in Length}}{\text{Original Length}}$$

$$e = \frac{\Delta}{L} \quad \dots(7)$$



**Fig. 7**

When changes in longitudinal direction is taking place changes in lateral direction also take place. The nature of these changes in lateral direction are exactly opposite to that of changes in longitudinal direction *i.e.*, if extension is taking place in longitudinal direction, the shortening of lateral dimension takes place and if shortening is taking place in longitudinal direction extension takes place in lateral directions (See Fig. 7). *The lateral strain may be defined as changes in the lateral dimension per unit lateral dimension.* Thus,

$$\text{Lateral Strain} = \frac{\text{Change in Lateral Dimension}}{\text{Original Lateral Dimension}}$$

$$= \frac{b' - b}{b} = \frac{\delta b}{b} \quad \dots(8)$$

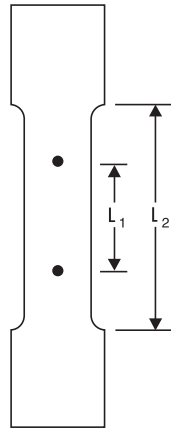
## STRESS-STRAIN RELATION

The stress-strain relation of any material is obtained by conducting tension test in the laboratories on standard specimen. Different materials behave differently and their behaviour in tension and in compression differ slightly.

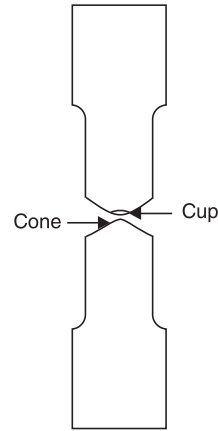
### Behaviour in Tension

**Mild steel.** Figure 8 shows a typical tensile test specimen of mild steel. Its ends are gripped into universal testing machine. Extensometer is fitted to test specimen which measures extension over the length  $L_1$ , shown in Fig. 8. The length over which extension is measured is called *gauge length*. The load is applied gradually and at regular interval of loads extension is measured. After certain load, extension increases at faster rate and the capacity of extensometer to measure extension comes to an end and, hence, it is removed before this stage is reached and extension is measured from scale machine. Load is increased gradually till the specimen breaks.





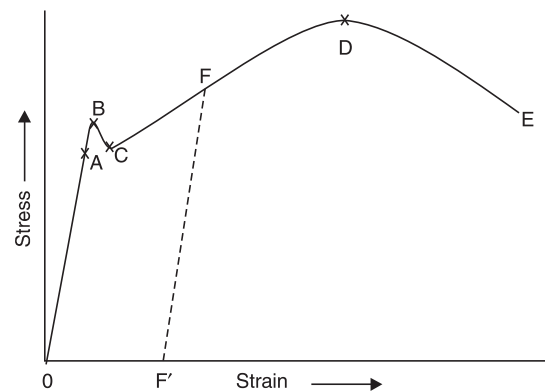
**Fig. 8.** Tension Test Specimen



**Fig. 9.** Tension Test Specimen after Breaking

Load divided by original cross-sectional area is called as nominal stress or simply as stress. Strain is obtained by dividing extensometer readings by gauge length of extensometer ( $L_1$ ) and by dividing scale readings by grip to grip length of the specimen ( $L_2$ ). Figure 8.10 shows stress vs strain diagram for the typical mild steel specimen. The following salient points are observed on stress-strain curve:

- (a) **Limit of Proportionality (A):** It is the limiting value of the stress up to which stress is proportional to strain.
- (b) **Elastic Limit:** This is the limiting value of stress up to which if the material is stressed and then released (unloaded) strain disappears completely and the original length is regained. This point is slightly beyond the limit of proportionality.
- (c) **Upper Yield Point (B):** This is the stress at which, the load starts reducing and the extension increases. This phenomenon is called yielding of material. At this stage strain is about 0.125 per cent and stress is about  $250 \text{ N/mm}^2$ .
- (d) **Lower Yield Point (C):** At this stage the stress remains same but strain increases for some time.
- (e) **Ultimate Stress (D):** This is the maximum stress the material can resist. This stress is about  $370\text{--}400 \text{ N/mm}^2$ . At this stage cross-sectional area at a particular section starts reducing very fast (Fig. 8.9). This is called neck formation. After this stage load resisted and hence the stress developed starts reducing.
- (f) **Breaking Point (E):** The stress at which finally the specimen fails is called breaking point. At this strain is 20 to 25 per cent.



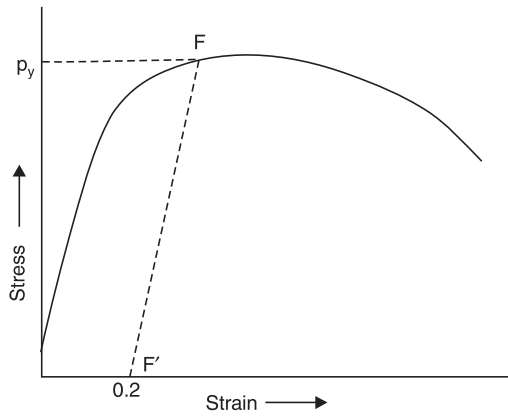
**Fig. 10**

If unloading is made within elastic limit the original length is regained *i.e.*, the stress-strain curve

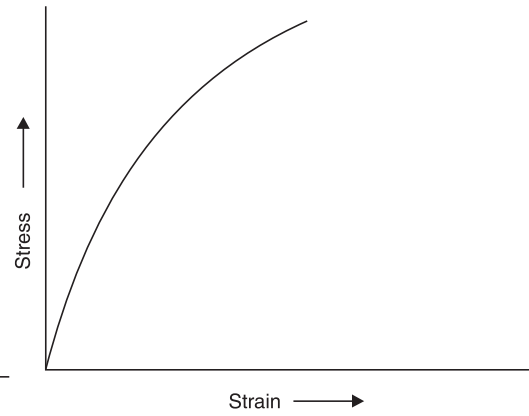
follows down the loading curve shown in Fig. 8.6. If unloading is made after loading the specimen beyond elastic limit, it follows a straight line parallel to the original straight portion as shown by line  $FF'$  in Fig. 10. Thus if it is loaded beyond elastic limit and then unloaded a permanent strain ( $OF$ ) is left in the specimen. This is called *permanent set*.

**Stress-strain relation in aluminium and high strength steel.** In these elastic materials there is no clear cut yield point. The necking takes place at ultimate stress and eventually the breaking point is lower than the ultimate point. The typical stress-strain diagram is shown in Fig. 11. The stress  $p$  at which if unloading is made there will be 0.2 per cent permanent set is known as 0.2 per cent proof stress and this point is treated as yield point for all practical purposes.





**Fig. 11.** Stress-Strain Relation in Aluminium and High Strength Steel



**Fig. 12.** Stress-Strain Relation for Brittle Material

**Stress-strain relation in brittle material.** The typical stress-strain relation in a brittle material like cast iron, is shown in Fig. 12.

In these material, there is no appreciable change in rate of strain. There is no yield point and no necking takes place. Ultimate point and breaking point are one and the same. The strain at failure is very small.

**Percentage elongation and percentage reduction in area.** Percentage elongation and percentage reduction in area are the two terms used to measure the ductility of material.

(a) **Percentage Elongation:** It is defined as the ratio of the final extension at rupture to original length expressed, as percentage. Thus,

$$\text{Percentage Elongation} = \frac{L' - L}{L} \times 100 \quad \dots(9)$$

where  $L$  – original length,  $L'$ – length at rupture.

The code specify that original length is to be five times the diameter and the portion considered must include neck (whenever it occurs). Usually marking are made on tension rod at every '2.5  $d$ ' distance and after failure the portion in which necking takes place is considered. In case of ductile material percentage elongation is 20 to 25.

(b) **Percentage Reduction in Area:** It is defined as the ratio of maximum changes in the cross-sectional area to original cross-sectional area, expressed as percentage. Thus,

$$\text{Percentage Reduction in Area} = \frac{A - A'}{A} \times 100 \quad \dots(10)$$

where  $A$ –original cross-sectional area,  $A'$ –minimum cross-sectional area. In case of ductile material,  $A'$  is calculated after measuring the diameter at the neck. For this, the two broken pieces of the specimen are to be kept joining each other properly. For steel, the percentage reduction in area is 60 to 70.

### Behaviour of Materials under Compression

As there is chance to bucking (laterally bending) of long specimen, for compression tests short specimens are used. Hence, this test involves measurement of smaller changes in length. It results into lesser accuracy. However precise measurements have shown the following results:

- (a) In case of ductile materials stress-strain curve follows exactly same path as in tensile test up to and even slightly beyond yield point. For larger values the curves diverge. There will not be necking in case of compression tests.
- (b) For most brittle materials ultimate compressive stress in compression is much larger than in tension. It is because of flows and cracks present in brittle materials which weaken the material in tension but will not affect the strength in compression.



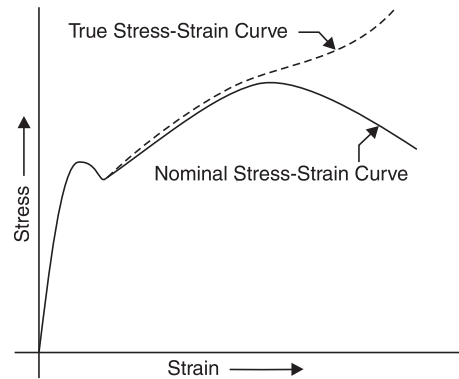
## NOMINAL STRESS AND TRUE STRESS

So far our discussion on direct stress is based on the value obtained by dividing the load by original cross-sectional area. That is the reason why the value of stress started dropping after neck is formed in mild steel (or any ductile material) as seen in Fig. 10. But actually as material is stressed its cross-sectional area changes. We should divide load by the actual cross-sectional area to get true stress in the material. To distinguish between the two values we introduce the terms nominal stress and true stress and define them as given below:

$$\text{Nominal Stress} = \frac{\text{Load}}{\text{Original Cross-sectional Area}} \quad \dots(11a)$$

$$\text{True Stress} = \frac{\text{Load}}{\text{Actual Cross-sectional Area}} \quad \dots(11b)$$

So far discussion was based on nominal stress. That is why after neck formation started (after ultimate stress), stress-strain curve started sloping down and the breaking took place at lower stress (nominal). If we consider true stress, it is increasing continuously as strain increases as shown in Fig. 13.



**Fig. 13.** Nominal Stress-Strain Curve and True Stress-Strain Curve for Mild Steel.

## FACTOR OF SAFETY

In practice it is not possible to design a mechanical component or structural component permitting stressing up to ultimate stress for the following reasons:

1. Reliability of material may not be 100 per cent. There may be small spots of flaws.
2. The resulting deformation may obstruct the functional performance of the component.
3. The loads taken by designer are only estimated loads. Occasionally there can be overloading. Unexpected impact and temperature loadings may act in the lifetime of the member.
4. There are certain ideal conditions assumed in the analysis (like boundary conditions). Actually ideal conditions will not be available and, therefore, the calculated stresses will not be 100 per cent real stresses.

Hence, *the maximum stress to which any member is designed is much less than the ultimate stress, and this stress is called Working Stress. The ratio of ultimate stress to working stress is called factor of safety.* Thus

$$\text{Factor of Safety} = \frac{\text{Ultimate Stress}}{\text{Working Stress}} \quad \dots(8.12)$$

In case of elastic materials, since excessive deformation create problems in the performance of the member, working stress is taken as a factor of yield stress or that of a 0.2 proof stress (if yield point do not exist).

Factor of safety for various materials depends up on their reliability. The following values are commonly taken in practice:

1. For steel – 1.85
2. For concrete – 3
3. For timber – 4 to 6



## HOOKE'S LAW

Robert Hooke, an English mathematician conducted several experiments and concluded that *stress is proportional to strain up to elastic limit*. This is called Hooke's law. Thus Hooke's law is, up to elastic limit

$$p \propto e \quad \dots\dots(13a)$$

where  $p$  is stress and  $e$  is strain

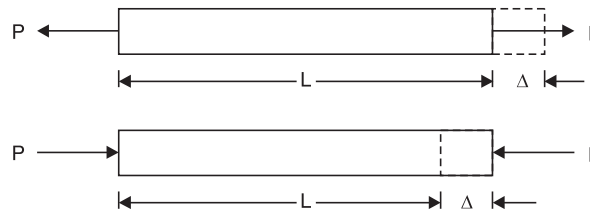
Hence, 
$$p = Ee \quad \dots(13b)$$

where  $E$  is the constant of proportionality of the material, known as modulus of elasticity or Young's modulus, named after the English scientist Thomas Young (1773–1829).

However, present day sophisticated experiments have shown that for mild steel the Hooke's law holds good up to the proportionality limit which is very close to the elastic limit. For other materials, Hooke's law does not hold good. However, in the range of working stresses, assuming Hooke's law to hold good, the relationship does not deviate considerably from actual behaviour. Accepting Hooke's law to hold good, simplifies the analysis and design procedure considerably. Hence Hooke's law is widely accepted. The analysis procedure accepting Hooke's law is known as Linear Analysis and the design procedure is known as the working stress method.

### EXTENSION/SHORTENING OF A BAR

Consider the bars shown in Fig. 14



**Fig. 14**

From equation (8.6), Stress 
$$p = \frac{P}{A}$$

From equation (8.7), Strain, 
$$e = \frac{\Delta}{L}$$

From Hooke's Law we have,

$$E = \frac{\text{Stress}}{\text{Strain}} = \frac{p}{e} = \frac{P/A}{\Delta/L} = \frac{PL}{A\Delta}$$

or 
$$\Delta = \frac{PL}{AE} \quad \dots(14)$$

**Example 1.** A circular rod of diameter 16 mm and 500 mm long is subjected to a tensile force 40 kN. The modulus of elasticity for steel may be taken as 200 kN/mm<sup>2</sup>. Find stress, strain and elongation of the bar due to applied load.

**Solution:**

Load  $P = 40 \text{ kN} = 40 \times 1000 \text{ N}$

$E = 200 \text{ kN/mm}^2 = 200 \times 10^3 \text{ N/mm}^2$

$L = 500 \text{ mm}$

Diameter of the rod  $d = 16 \text{ mm}$

Therefore, sectional area 
$$A = \frac{\pi d^2}{4} = \frac{\pi}{4} \times 16^2$$

$$= 201.06 \text{ mm}^2$$



$$\text{Stress } p = \frac{P}{A} = \frac{40 \times 1000}{201.06} = 198.94 \text{ N/mm}^2$$

$$\text{Strain } e = \frac{p}{E} = \frac{198.94}{200 \times 10^3} = 0.0009947$$

$$\text{Elongation } \Delta = \frac{PL}{AE} = \frac{4.0 \times 1000 \times 500}{201.06 \times 200 \times 10^3} = 0.497 \text{ mm}$$

**Example 2.** A Surveyor's steel tape 30 m long has a cross-section of 15 mm × 0.75 mm. With this, line AB is measure as 150 m. If the force applied during measurement is 120 N more than the force applied at the time of calibration, what is the actual length of the line?

Take modulus of elasticity for steel as 200 kN/mm<sup>2</sup>.

**Solution:**

$$A = 15 \times 0.75 = 11.25 \text{ mm}^2$$

$$P = 120 \text{ N}, L = 30 \text{ m} = 30 \times 1000 \text{ mm}$$

$$E = 200 \text{ kN/mm}^2 = 200 \times 10^3 \text{ N/mm}^2$$

$$\text{Elongation } \Delta = \frac{PL}{AE} = \frac{120 \times 30 \times 1000}{11.25 \times 200 \times 10^3} = 1.600 \text{ mm}$$

Hence, if measured length is 30 m.

Actual length is 30 m + 1.600 mm = 30.001600 m

$$\therefore \text{ Actual length of line AB} = \frac{150}{30} \times 30.001600 = 150.008 \text{ m}$$

**Example 3.** A hollow steel tube is to be used to carry an axial compressive load of 160 kN. The yield stress for steel is 250 N/mm<sup>2</sup>. A factor of safety of 1.75 is to be used in the design. The following three class of tubes of external diameter 101.6 mm are available.

Class	Thickness
Light	3.65 mm
Medium	4.05 mm
Heavy	4.85 mm

Which section do you recommend?

**Solution:** Yield stress = 250 N/mm<sup>2</sup>

Factor of safety = 1.75

Therefore, permissible stress

$$p = \frac{250}{1.75} = 142.857 \text{ N/mm}^2$$

$$\text{Load } P = 160 \text{ kN} = 160 \times 10^3 \text{ N}$$

but

$$p = \frac{P}{A}$$

$$\text{i.e. } 142.857 = \frac{160 \times 10^3}{A}$$

$$\therefore A = \frac{160 \times 10^3}{142.857} = 1120 \text{ mm}^2$$

For hollow section of outer diameter 'D' and inner diameter 'd'

$$A = \frac{\pi}{4}(D^2 - d^2) = 1120$$

$$\frac{\pi}{4}(101.6^2 - d^2) = 1120$$





$$d^2 = 8896.53 \quad \therefore d = 94.32 \text{ mm}$$

$$\therefore t = \frac{D-d}{2} = \frac{101.6 - 94.32}{2} = 3.63 \text{ mm}$$

**Hence, use of light section is recommended.**

**Example 4.** A specimen of steel 20 mm diameter with a gauge length of 200 mm is tested to destruction. It has an extension of 0.25 mm under a load of 80 kN and the load at elastic limit is 102 kN. The maximum load is 130 kN.

The total extension at fracture is 56 mm and diameter at neck is 15 mm. Find

- (i) The stress at elastic limit.
- (ii) Young's modulus.
- (iii) Percentage elongation.
- (iv) Percentage reduction in area.
- (v) Ultimate tensile stress.

**Solution:** Diameter  $d = 20 \text{ mm}$

$$\text{Area } A = \frac{\pi d^2}{4} = 314.16 \text{ mm}^2$$

$$\begin{aligned} \text{(i) Stress at elastic limit} &= \frac{\text{Load at elastic limit}}{\text{Area}} \\ &= \frac{102 \times 10^3}{314.16} = 324.675 \text{ N/mm}^2 \end{aligned}$$

$$\begin{aligned} \text{(ii) Young's modulus } E &= \frac{\text{Stress}}{\text{Strain}} \text{ within elastic limit} \\ &= \frac{P/A}{\Delta/L} = \frac{80 \times 10^3 / 314.16}{0.25/200} \\ &= 203718 \text{ N/mm}^2 \end{aligned}$$

$$\begin{aligned} \text{(iii) Percentage elongation} &= \frac{\text{Final extension}}{\text{Original length}} \\ &= \frac{56}{200} \times 100 = 28 \end{aligned}$$

$$\begin{aligned} \text{(iv) Percentage reduction in area} &= \frac{\text{Initial area} - \text{Final area}}{\text{Initial area}} \times 100 \\ &= \frac{\frac{\pi}{4} \times 20^2 - \frac{\pi}{4} \times 15^2}{\frac{\pi}{4} \times 20^2} \times 100 = 43.75 \end{aligned}$$

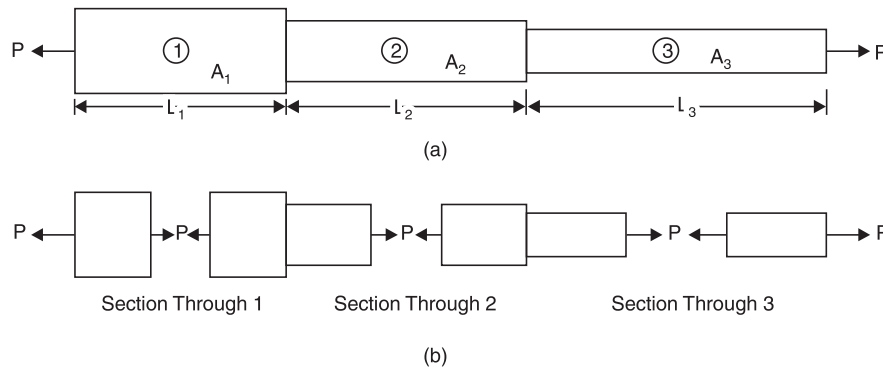
$$\begin{aligned} \text{(v) Ultimate Tensile Stress} &= \frac{\text{Ultimate Load}}{\text{Area}} \\ &= \frac{130 \times 10^3}{314.16} = 413.80 \text{ N/mm}^2. \end{aligned}$$



## BARS WITH CROSS-SECTIONS VARYING IN STEPS

A typical bar with cross-sections varying in steps and subjected to axial load is as shown in Fig. 15(a). Let the length of three portions be  $L_1$ ,  $L_2$  and  $L_3$  and the respective cross-sectional areas of the portion be  $A_1$ ,  $A_2$ ,  $A_3$  and  $E$  be the Young's modulus of the material and  $P$  be the applied axial load.

Figure 15(b) shows the forces acting on the cross-sections of the three portions. It is obvious that to maintain equilibrium the load acting on each portion is  $P$  only. Hence stress, strain and extension of each of these portions are as listed below:



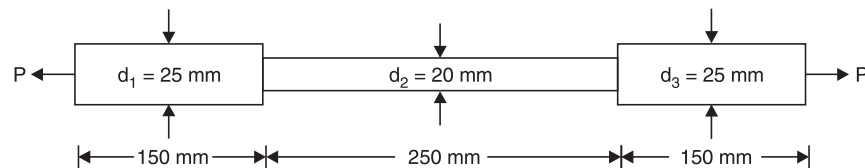
**Fig.15.** Typical Bar with Cross-section Varying in Step

Portion	Stress	Strain	Extension
1	$p_1 = \frac{P}{A_1}$	$e_1 = \frac{p_1}{E} = \frac{P}{A_1 E}$	$\Delta_1 = \frac{PL_1}{A_1 E}$
2	$p_2 = \frac{P}{A_2}$	$e_2 = \frac{p_2}{E} = \frac{P}{A_2 E}$	$\Delta_2 = \frac{PL_2}{A_2 E}$
3	$p_3 = \frac{P}{A_3}$	$e_3 = \frac{p_3}{E} = \frac{P}{A_3 E}$	$\Delta_3 = \frac{PL_3}{A_3 E}$

Hence total change in length of the bar

$$\Delta = \Delta_1 + \Delta_2 + \Delta_3 = \frac{PL_1}{A_1 E} + \frac{PL_2}{A_2 E} + \frac{PL_3}{A_3 E} \quad \dots(15)$$

**Example 5.** The bar shown in Fig. 16 is tested in universal testing machine. It is observed that at a load of 40 kN the total extension of the bar is 0.280 mm. Determine the Young's modulus of the material.



**Fig. 16**

**Solution:** Extension of portion 1,

$$\frac{PL_1}{A_1 E} = \frac{40 \times 10^3 \times 150}{\frac{\pi}{4} \times 25^2 E}$$

Extension of portion 2,

$$\frac{PL_2}{A_2 E} = \frac{40 \times 10^3 \times 250}{\frac{\pi}{4} \times 20^2 E}$$



Extension of portion 3, 
$$\frac{PL_3}{A_3E} = \frac{40 \times 10^3 \times 150}{\frac{\pi}{4} \times 25^2 E}$$

$$\text{Total extension} = \frac{40 \times 10^3}{E} \times \frac{4}{\pi} \left\{ \frac{150}{625} + \frac{250}{400} + \frac{150}{625} \right\}$$

$$0.280 = \frac{40 \times 10^3}{E} \times \frac{4}{\pi} \times \frac{1.112}{E}$$

$$E = 200990 \text{ N/mm}^2$$

### BARS WITH CONTINUOUSLY VARYING CROSS-SECTIONS

When the cross-section varies continuously, an elemental length of the bar should be considered and general expression for elongation of the elemental length derived. Then the general expression should be integrated over entire length to get total extension.

**Example 8.** A bar of uniform thickness 't' tapers uniformly from a width of  $b_1$  at one end to  $b_2$  at other end in a length 'L' as shown in Fig. 18. Find the expression for the change in length of the bar when subjected to an axial force P.

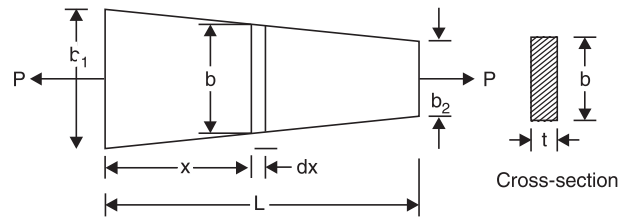


Fig. 19

**Solution:** Consider an elemental length  $dx$  at a distance  $x$  from larger end. Rate of change of breadth is  $\frac{b_1 - b_2}{L}$ .

Hence, width at section  $x$  is  $b = b_1 - \frac{b_1 - b_2}{L} x = b_1 - kx$

where  $k = \frac{b_1 - b_2}{L}$

$\therefore$  Cross-section area of the element =  $A = t(b_1 - kx)$

Since force acting at all sections is  $P$  only,

Extension of element =  $\frac{Pdx}{AE}$  [where length =  $dx$ ]

$$= \frac{Pdx}{(b_1 - kx)tE}$$

**Total extension of the bar** =  $\int_0^L \frac{Pdx}{(b_1 - kx)tE} = \frac{P}{tE} \int_0^L \frac{dx}{(b_1 - kx)}$

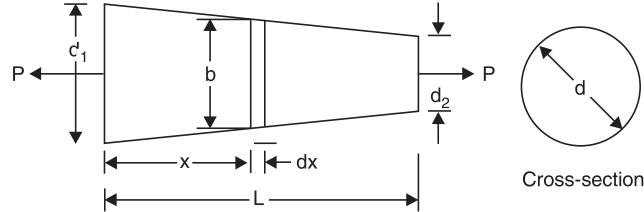
$$= \frac{P}{tE} \left( \frac{1}{-k} \right) \left[ \log (b_1 - kx) \right]_0^L$$

$$= \frac{P}{tEk} \left[ -\log \left( b_1 - \frac{b_1 - b_2}{L} x \right) \right]_0^L$$



$$\begin{aligned}
&= \frac{P}{tEk} [-\log b_2 + \log b_1] = \frac{P}{tEk} \log \frac{b_1}{b_2} \\
&= \frac{PL}{tE(b_1 - b_2)} \log \frac{b_1}{b_2}. \quad \dots(16)
\end{aligned}$$

A tapering rod has diameter  $d_1$  at one end and it tapers uniformly to a diameter  $d_2$  at the other end in a length  $L$  as shown in Fig. 20. If modulus of elasticity of the material is  $E$ , find its change in length when subjected to an axial force  $P$ .



**Fig. 20**

**Solution:** Change in diameter in length  $L$  is  $d_1 - d_2$

$$\therefore \text{Rate of change of diameter, } k = \frac{d_1 - d_2}{L}$$

Consider an elemental length of bar  $dx$  at a distance  $x$  from larger end. The diameter of the bar at this section is

$$d = d_1 - kx.$$

$$\text{Cross-sectional area } A = \frac{\pi d^2}{4} = \frac{\pi}{4} (d_1 - kx)^2$$

$$\therefore \text{Extension of the element} = \frac{P dx}{\frac{\pi}{4} (d_1 - kx)^2 E}$$

$$\begin{aligned}
\text{Extension of the entire bar } \Delta &= \int_0^L \frac{P dx}{\frac{\pi}{4} (d_1 - kx)^2 E} \\
&= \frac{4P}{\pi E} \int_0^L \frac{dx}{(d_1 - kx)^2} \\
&= \frac{4P}{\pi E k} \left( \frac{1}{d_1 - kx} \right)_0^L \\
&= \frac{4P}{\pi E (d_1 - d_2)} \left( \frac{1}{d_2} - \frac{1}{d_1} \right), \text{ since } d_1 - kL = d_2
\end{aligned}$$

$$\Delta = \frac{4PL}{\pi E (d_1 - d_2)} \times \frac{(d_1 - d_2)}{d_1 d_2} = \frac{4PL}{\pi E d_1 d_2}. \quad \dots(17)$$



**Example 6.** A steel flat of thickness 10 mm tapers uniformly from 60 mm at one end to 40 mm at other end in a length of 600 mm. If the bar is subjected to a load of 80 kN, find its extension. Take  $E = 2 \times 10^5$  MPa. What is the percentage error if average area is used for calculating extension?

**Solution:** Now,  $t = 10$  mm       $b_1 = 60$  mm       $b_2 = 40$  mm  
 $L = 600$  mm       $P = 80$  kN = 80000 N

Now,  $1$  MPa =  $1$  N/mm<sup>2</sup>  
Hence  $E = 2 \times 10^5$  N/mm<sup>2</sup>

Extension of the tapering bar of rectangular section

$$\begin{aligned} \Delta &= \frac{PL}{tE(b_1 - b_2)} \log \frac{b_1}{b_2} \\ &= \frac{80000 \times 600}{10 \times 2 \times 10^5 (60 - 40)} \log \frac{60}{40} \\ &= \mathbf{0.4865 \text{ mm}} \end{aligned}$$

If averages cross-section is considered instead of tapering cross-section, extension is given by

$$\Delta = \frac{PL}{A_{av}E}$$

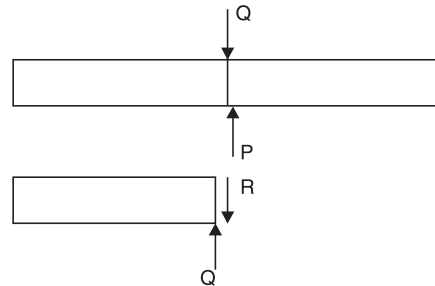
Now  $A_{av} = \frac{60 \times 10 + 40 \times 10}{2} = 500$  mm<sup>2</sup>

$$\Delta = \frac{80000 \times 600}{500 \times 2 \times 10^5} = 0.480 \text{ mm}$$

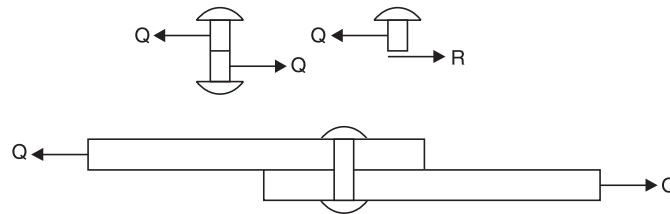
$$\begin{aligned} \therefore \text{Percentage error} &= \frac{0.4865 - 0.48}{0.4865} \times 100 \\ &= \mathbf{1.348} \end{aligned}$$

### SHEAR STRESS

Figure 22 shows a bar subject to direct shearing force *i.e.*, the force parallel to the cross-section of bar. The section of a rivet/bolt subject to direct shear is shown in Fig. 23. Let  $Q$  be the shearing force and  $q$  the shearing stress acting on the section. Then, with usual assumptions that stresses are uniform we get,



**Fig. 22.** Direct Shear Force on a Section



**Fig. 23.** Rivet in Direct Shear

$$R = \int q \, dA = q \int dA = qA$$

For equilibrium  $Q = R = qA$

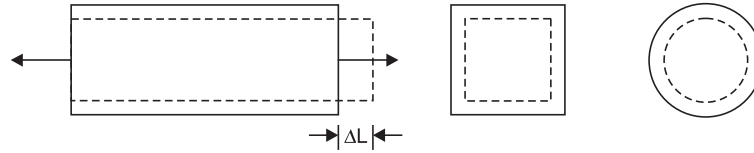
$$\text{i.e.,} \quad q = \frac{Q}{A} \quad \dots(18)$$

Thus, the direct stress is equal to shearing force per unit area.



## POISSON'S RATIO

When a material undergoes changes in length, it undergoes changes of opposite nature in lateral directions. For example, if a bar is subjected to direct tension in its axial direction it elongates and at the same time its sides contract (Fig. 27).



**Fig. 27.** Changes in Axial and Lateral Directions

If we define the ratio of change in axial direction to original length as linear strain and change in lateral direction to the original lateral dimension as lateral strain, it is found that *within elastic limit there is a constant ratio between lateral strain and linear strain. This constant ratio is called Poisson's ratio.* Thus,

$$\text{Poisson's ratio} = \frac{\text{Lateral strain}}{\text{Linear strain}} \quad \dots(19)$$

It is denoted by  $\frac{1}{m}$ , or  $\mu$ . For most of metals its value is between 0.25 to 0.33. Its value for steel is 0.3 and for concrete 0.15.

## VOLUMETRIC STRAIN

When a member is subjected to stresses, it undergoes deformation in all directions. Hence, there will be change in volume. The *ratio of the change in volume to original volume is called volumetric strain.*

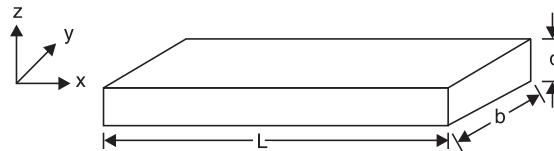
$$\text{Thus} \quad e_v = \frac{\delta V}{V} \quad \dots(20)$$

where  $e_v$  = Volumetric strain  
 $\delta V$  = Change in volume  
 $V$  = Original volume

It can be shown that volumetric strain is sum of strains in three mutually perpendicular directions. *i.e.,*

$$e_v = e_x + e_y + e_z$$

For example consider a bar of length  $L$ , breadth  $b$  and depth  $d$  as shown in Fig. 28.



**Fig. 28**

Now,  $V = Lbd$   
 Since volume is function of  $L$ ,  $b$  and  $d$ .

$$\delta V = \delta L \, bd + L \, \delta b \, d + Lb \, \delta d$$

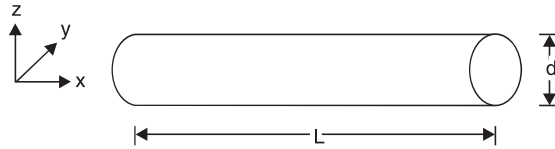
$$\frac{\delta V}{V} = \frac{\delta v}{Lbd}$$

$$e_v = \frac{\delta L}{L} + \frac{\delta b}{b} + \frac{\delta d}{d}$$

$$e_v = e_x + e_y + e_z$$

Now, consider a circular rod of length  $L$  and diameter ' $d$ ' as shown in Fig. 29.





**Fig. 29**

Volume of the bar  $V = \frac{\pi}{4} d^2 L$

$\therefore \delta V = \frac{\pi}{4} 2d\delta d L + \frac{\pi}{4} d^2 \delta L$  (since  $v$  is function of  $d$  and  $L$ ).

$\therefore \frac{\delta V}{\frac{\pi}{4} d^2 L} = 2 \frac{\delta d}{d} + \frac{\delta L}{L}$

$e_v = e_x + e_y + e_z$ ; since  $e_y = e_z = \frac{\delta d}{d}$

In general for any shape *volumetric strain may be taken as sum of strains in three mutually perpendicular directions.*

### ELASTIC CONSTANTS

Modulus of elasticity, modulus of rigidity and bulk modulus are the three elastic constants. Modulus of elasticity (Young's Modulus) 'E' has been already defined as the ratio of linear stress to linear strain within elastic limit. Rigidity modulus and Bulk modulus are defined in this article.

**Modulus of Rigidity:** It is defined as the *ratio of shearing stress to shearing strain within elastic limit and is usually denoted by letter G or N.* Thus

$$G = \frac{q}{\phi} \quad \dots(21)$$

where  $G$  = Modulus of rigidity  
 $q$  = Shearing stress  
 and  $\phi$  = Shearing strain

**Bulk Modulus:** When a body is subjected to identical stresses  $p$  in three mutually perpendicular directions, (Fig. 30), the body undergoes uniform changes in three directions without undergoing distortion of shape. The ratio of change in volume to original volume has been defined as volumetric strain ( $e_v$ ). Then the bulk modulus,  $K$  is defined as

$$K = \frac{p}{e_v}$$

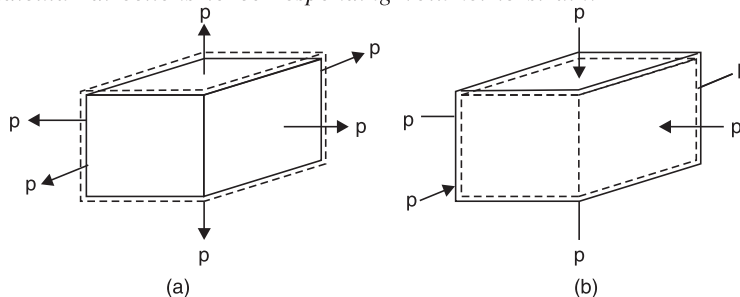
where  $p$  = identical pressure in three mutually perpendicular directions

$e_v = \frac{\Delta_v}{v}$ , Volumetric strain

$\Delta_v$  = Change in volume

$v$  = Original volume

*Thus bulk modulus may be defined as the ratio of identical pressure 'p' acting in three mutually perpendicular directions to corresponding volumetric strain.*



**Fig. 30**



Figure 30 shows a body subjected to identical compressive pressure 'p' in three mutually perpendicular directions. Since hydrostatic pressure, the pressure exerted by a liquid on a body within it, has this nature of stress, such a pressure 'p' is called as hydrostatic pressure.

### RELATIONSHIP BETWEEN MODULUS OF ELASTICITY AND MODULUS OF RIGIDITY

Consider a square element ABCD of sides 'a' subjected to pure shear 'q' as shown in Fig. 8.31. AEC'D shown is the deformed shape due to shear q. Drop perpendicular BF to diagonal DE. Let  $\phi$  be the shear strain and G modulus of rigidity.

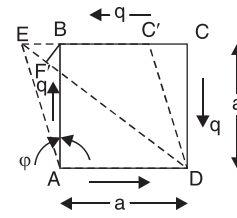


Fig. 31

$$\begin{aligned} \text{Now, strain in diagonal } BD &= \frac{DE - DF}{DF} \\ &= \frac{EF}{DB} \\ &= \frac{EF}{AB\sqrt{2}} \end{aligned}$$

Since angle of deformation is very small we can assume  $\angle BEF = 45^\circ$ , hence  $EF = BE \cos 45^\circ$

$$\begin{aligned} \therefore \text{ Strain in diagonal } BD &= \frac{EF}{BD} = \frac{BE \cos 45^\circ}{AB\sqrt{2}} \\ &= \frac{a \tan \phi \cos 45^\circ}{a\sqrt{2}} \\ &= \frac{1}{2} \tan \phi = \frac{1}{2} \phi \quad (\text{Since } \phi \text{ is very small}) \\ &= \frac{1}{2} \times \frac{q}{G}, \text{ since } \phi = \frac{q}{G} \quad \dots(1) \end{aligned}$$

Now, we know that the above pure shear gives rise to axial tensile stress  $q$  in the diagonal direction of  $DB$  and axial compression  $q$  at right angles to it. These two stresses cause tensile strain along the diagonal  $DB$ .

$$\text{Tensile strain along the diagonal } DB = \frac{q}{E} + \mu \frac{q}{E} = \frac{q}{E}(1 + \mu) \quad \dots(2)$$

From equations (1) and (2), we get

$$\begin{aligned} \frac{1}{2} \times \frac{q}{G} &= \frac{q}{E}(1 + \mu) \\ E &= 2G(1 + \mu) \quad \dots(22) \end{aligned}$$

### RELATIONSHIP BETWEEN MODULUS OF ELASTICITY AND BULK MODULUS

Consider a cubic element subjected to stresses  $p$  in the three mutually perpendicular direction  $x$ ,  $y$ ,  $z$  as shown in Fig. 32.

Now the stress  $p$  in  $x$  direction causes tensile strain  $\frac{p}{E}$  in  $x$  direction while the stress  $p$  in  $y$  and  $z$  direction cause compressive strains  $\mu \frac{p}{E}$  in  $x$  direction.

$$\begin{aligned} \text{Hence, } e_x &= \frac{p}{E} - \mu \frac{p}{E} - \mu \frac{p}{E} \\ &= \frac{p}{E}(1 - 2\mu) \end{aligned}$$

$$\text{Similarly } e_y = \frac{p}{E}(1 - 2\mu)$$

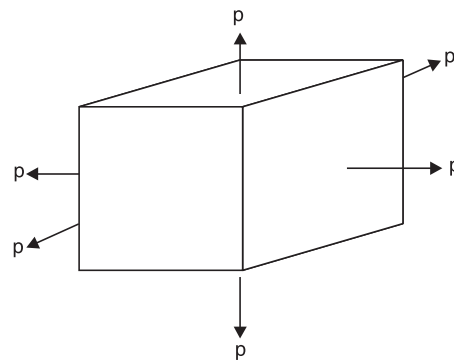


Fig. 32





$$e_z = \frac{p}{E}(1 - 2\mu) \quad \dots(1)$$

$$\therefore \text{Volumetric strain } e_v = e_x + e_y + e_z = \frac{3p}{E}(1 - 2\mu)$$

From definition, bulk modulus  $K$  is given by

$$K = \frac{p}{e_v} = \frac{p}{\frac{3p(1 - 2\mu)}{E}}$$

$$\text{or } E = 3K(1 - \mu) \quad \dots(2)$$

*Relationship between EGK:*

$$\text{We know } E = 2G(1 + \mu) \quad \dots(a)$$

$$\text{and } E = 3K(1 - 2\mu) \quad \dots(b)$$

By eliminating  $\mu$  between the above two equations we can get the relationship between  $E$ ,  $G$ ,  $K$ , free from the term  $\mu$ .

$$\text{From equation (a) } \mu = \frac{E}{2G} - 1$$

Substituting it in equation (b), we get

$$\begin{aligned} E &= 3K \left[ 1 - 2 \left( \frac{E}{2G} - 1 \right) \right] \\ &= 3K \left( 1 - \frac{E}{G} + 2 \right) = 3K \left( 3 - \frac{E}{G} \right) \\ &= 9K - \frac{3KE}{G} \end{aligned}$$

$$\therefore E \left( 1 + \frac{3K}{G} \right) = 9K$$

$$\text{or } E \left( \frac{G + 3K}{G} \right) = 9K \quad \dots(c)$$

$$\text{or } E = \frac{9KG}{G + 3K} \quad \dots(23a)$$

Equation (c) may be expressed as

$$\frac{9}{E} = \frac{G + 3K}{KG}$$



**Example 7.** A circular rod of 25 mm diameter and 500 mm long is subjected to a tensile force of 60 kN. Determine modulus of rigidity, bulk modulus and change in volume if Poisson's ratio = 0.3 and Young's modulus  $E = 2 \times 10^5 \text{ N/mm}^2$ .

**Solution:** From the relationship

$$E = 2G(1 + \mu) = 3k(1 - 2\mu)$$

We get,

$$G = \frac{E}{2(1 + \mu)} = \frac{2 \times 10^5}{2(1 + 0.3)} = 0.7692 \times 10^5 \text{ N/mm}^2$$

and

$$K = \frac{E}{3(1 + 2\mu)} = \frac{2 \times 10^5}{3(1 - 2 \times 0.3)} = 1.667 \times 10^5 \text{ N/mm}^2$$

$$\text{Longitudinal stress} = \frac{P}{A} = \frac{60 \times 10^3}{\frac{\pi}{4} \times 25^2} = 122.23 \text{ N/mm}^2$$

$$\text{Linear strain} = \frac{\text{Stress}}{E} = \frac{122.23}{2 \times 10^5} = 61.115 \times 10^{-5}$$

$$\text{Lateral strain} = e_y = -\mu e_x \quad \text{and} \quad e_z = -\mu e_x$$

$$\text{Volumetric strain } e_v = e_x + e_y + e_z$$

$$\begin{aligned} &= e_x(1 - 2\mu) \\ &= 61.115 \times 10^{-5} (1 - 2 \times 0.3) \\ &= 24.446 \times 10^{-5} \end{aligned}$$

$$\text{but } \frac{\text{Change in volume}}{v}$$

$$\begin{aligned} \therefore \text{Change in volume} &= e_v \times v \\ &= 24.446 \times 10^{-5} \times \frac{\pi}{4} \times (25^2) \times 500 \\ &= 60 \text{ mm}^3 \end{aligned}$$

**Example 8.** A 400 mm long bar has rectangular cross-section 10 mm  $\times$  30 mm. This bar is subjected to

- (i) 15 kN tensile force on 10 mm  $\times$  30 mm faces,
- (ii) 80 kN compressive force on 10 mm  $\times$  400 mm faces, and
- (iii) 180 kN tensile force on 30 mm  $\times$  400 mm faces.

Find the change in volume if  $E = 2 \times 10^5 \text{ N/mm}^2$  and  $\mu = 0.3$ .

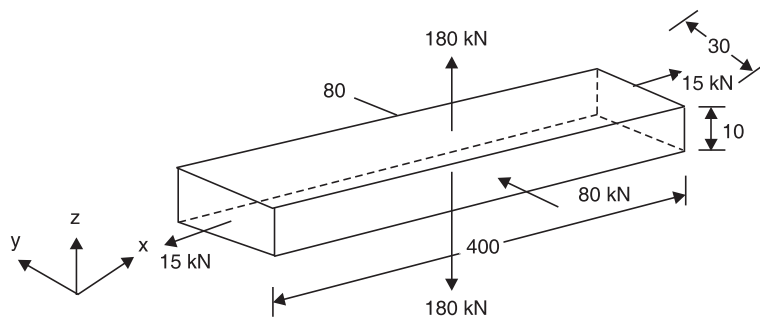


Fig 33



**Example 9.** In a laboratory, tensile test is conducted and Young's modulus of the material is found to be  $2.1 \times 10^5 \text{ N/mm}^2$ . On the same material torsion test is conducted and modulus of rigidity is found to be  $0.78 \times 10^5 \text{ N/mm}^2$ . Determine Poisson's Ratio and bulk modulus of the material.

[Note: This is usual way of finding material properties in the laboratory].

**Solution:**

$$E = 2.1 \times 10^5 \text{ N/mm}^2$$

$$G = 0.78 \times 10^5 \text{ N/mm}^2$$

Using relation

$$E = 2G(1 + \mu)$$

we get

$$2.1 \times 10^5 = 2 \times 0.78 \times 10^5 (1 + \mu)$$

$$1.346 = 1 + \mu$$

or

$$\mu = \mathbf{0.346}$$

From relation

$$E = 3K(1 - 2\mu)$$

we get

$$2.1 \times 10^5 = 3 \times K(1 - 2 \times 0.346)$$

$$K = \mathbf{2.275 \times 10^5 \text{ N/mm}^2}$$

**Example 10.** A material has modulus of rigidity equal to  $0.4 \times 10^5 \text{ N/mm}^2$  and bulk modulus equal to  $0.8 \times 10^5 \text{ N/mm}^2$ . Find its Young's Modulus and Poisson's Ratio.

**Solution:**

$$G = 0.4 \times 10^5 \text{ N/mm}^2$$

$$K = 0.8 \times 10^5 \text{ N/mm}^2$$

Using the relation  $E = \frac{9GK}{3K + G}$

$$E = \frac{9 \times 0.4 \times 10^5 \times 0.8 \times 10^5}{3 \times 0.8 \times 10^5 + 0.4 \times 10^5}$$

$$E = \mathbf{1.0286 \times 10^5 \text{ N}}$$

From the relation

$$E = 2G(1 + \mu)$$

we get

$$1.0286 \times 10^5 = 2 \times 0.4 \times 10^5(1 + \mu)$$

$$1.2857 = 1 + \mu$$

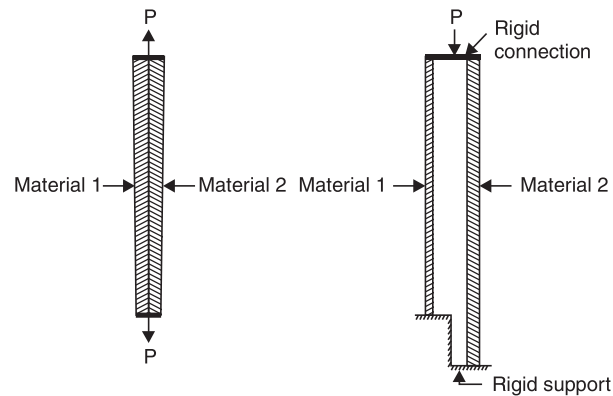
or

$$\mu = \mathbf{0.2857}$$



## COMPOSITE/COMPOUND BARS

Bars made up of two or more materials are called composite/compound bars. They may have same length or different lengths as shown in Fig. 34. The ends of different materials of the bar are held together under loaded conditions.



**Fig. 34**

Consider a member with two materials. Let the load shared by material 1 be  $P_1$  and that by material 2 be  $P_2$ . Then

(i) From equation of equilibrium of the forces, we get

$$P = P_1 + P_2 \quad \dots 24a)$$

(ii) Since the ends are held securely, we get

$$\Delta l_1 = \Delta l_2$$

where  $\Delta l_1$  and  $\Delta l_2$  are the extension of the bars of material 1 and 2 respectively

$$i.e. \quad \frac{P_1 L_1}{A_1 E_1} = \frac{P_2 L_2}{A_2 E_2} \quad \dots 24b)$$

Using equations 8.24(a) and (b),  $P_1$  and  $P_2$  can be found uniquely. Then extension of the system can be found using the relation  $\Delta l = \frac{P_1 L_1}{A_1 E_1}$  or  $\Delta l = \frac{P_2 L_2}{A_2 E_2}$  since  $\Delta l = \Delta l_1 = \Delta l_2$ .

The procedure of the analysis of compound bars is illustrated with the examples below:

**Example 11.** A compound bar of length 600 mm consists of a strip of aluminium 40 mm wide and 20 mm thick and a strip of steel 60 mm wide  $\times$  15 mm thick rigidly joined at the ends. If elastic modulus of aluminium and steel are  $1 \times 10^5$  N/mm<sup>2</sup> and  $2 \times 10^5$  N/mm<sup>2</sup>, determine the stresses developed in each material and the extension of the compound bar when axial tensile force of 60 kN acts.

**Solution:** The compound bar is shown in the figure 8.36.

Data available is

$$\begin{aligned} L &= 600 \text{ mm} \\ P &= 60 \text{ kN} = 60 \times 1000 \text{ N} \\ A_a &= 40 \times 20 = 800 \text{ mm}^2 \\ A_s &= 60 \times 15 = 900 \text{ mm}^2 \\ E_a &= 1 \times 10^5 \text{ N/mm}^2, E_s = 2 \times 10^5 \text{ N/mm}^2. \end{aligned}$$



Let the load shared by aluminium strip be  $P_a$  and that shared by steel be  $P_s$ . Then from equilibrium condition

$$P_a + P_s = 60 \times 1000 \quad \dots(1)$$

From compatibility condition, we have

$$\Delta_a = \Delta_s$$

$$\frac{P_a L}{A_a E_a} = \frac{P_s L}{A_s E_s}$$

$$i.e. \quad \frac{P_a \times 600}{800 \times 1 \times 10^5} = \frac{P_s \times 600}{900 \times 2 \times 10^5}$$

$$P_s = 2.25 P_a \quad \dots(2)$$

Substituting it in eqn. (1), we get

$$P_a + 2.25 P_a = 60 \times 1000$$

$$i.e. \quad P_a = 18462 \text{ N.}$$

$$\therefore P_s = 2.25 \times 18462 = 41538 \text{ N.}$$

$$\therefore \text{Stress in aluminium strip} = \frac{P_a}{A_a} = \frac{18462}{800} \\ = 23.08 \text{ N/mm}^2$$

$$\text{Stress in steel strip} = \frac{P_s}{A_s} = \frac{41538}{900} = 46.15 \text{ N/mm}^2$$

$$\text{Extension of the compound bar} = \frac{P_a L}{A_a E_a} = \frac{18462 \times 600}{800 \times 1 \times 10^5}$$

$$\Delta l = 0.138 \text{ mm.}$$

**Example 12.** A compound bar consists of a circular rod of steel of 25 mm diameter rigidly fixed into a copper tube of internal diameter 25 mm and external diameter 40 mm as shown in Fig. 36. If the compound bar is subjected to a load of 120 kN, find the stresses developed in the two materials.

$$\text{Take } E_s = 2 \times 10^5 \text{ N/mm}^2 \\ \text{and } E_c = 1.2 \times 10^5 \text{ N/mm}^2.$$

$$\text{Solution: Area of steel rod } A_s = \frac{\pi}{4} \times 25^2 = 490.87 \text{ mm}^2$$

$$\text{Area of copper tube } A_c = \frac{\pi}{4} (40^2 - 25^2) = 765.76 \text{ mm}^2$$

From equation of equilibrium,

$$P_s + P_c = 120 \times 1000 \quad \dots(1)$$

where  $P_s$  is the load shared by steel rod and  $P_c$  is the load shared by the copper tube.

From compatibility condition, we have

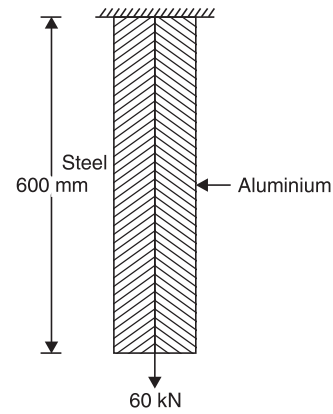
$$\Delta_s = \Delta_c$$

$$\frac{P_s L}{A_s E_s} = \frac{P_c L}{A_c E_c}$$

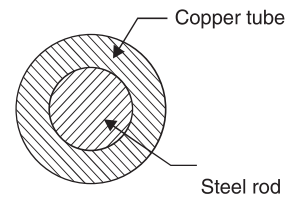
$$\frac{P_s}{490.87 \times 2 \times 10^5} = \frac{P_c}{765.76 \times 1.2 \times 10^5}$$

$$\therefore P_s = 1.068 P_c \quad \dots(2)$$

From eqns. (1) and (2), we get



**Fig. 35**



**Fig. 36**



$$1.068 P_c + P_c = 120 \times 1000$$

$$\therefore \frac{P_c}{2.068} = \frac{120 \times 1000}{2.068} = 58027 \text{ N}$$

$$\therefore P_s = 1.068 P_c = 61973 \text{ N}$$

$$\therefore \text{Stress in copper} = \frac{58027}{9765.76} = 75.78 \text{ N/mm}^2$$

$$\text{Stress in steel} = \frac{61973}{490.87} = 126.25 \text{ N/mm}^2$$

**Example 13.** Three pillars, two of aluminium and one of steel support a rigid platform of 250 kN as shown in Fig. 38. If area of each aluminium pillar is 1200 mm<sup>2</sup> and that of steel pillar is 1000 mm<sup>2</sup>, find the stresses developed in each pillar.

Take  $E_s = 2 \times 10^5 \text{ N/mm}^2$  and  $E_a = 1 \times 10^6 \text{ N/mm}^2$ .

**Solution:** Let force shared by each aluminium pillar be  $P_a$  and that shared by steel pillar be  $P_s$ .

$\therefore$  The forces in vertical direction = 0  $\rightarrow$

$$P_a + P_s + P_a = 250$$

$$2P_a + P_s = 250 \quad \dots(1)$$

From compatibility condition, we get

$$\Delta_s = \Delta_a$$

$$\frac{P_s L_s}{A_s E_s} = \frac{P_a L_a}{A_a E_a}$$

$$\frac{P_s \times 240}{1000 \times 2 \times 10^5} = \frac{P_a \times 160}{1200 \times 1 \times 10^5}$$

$$\therefore P_s = 1.111 P_a \quad \dots(2)$$

From eqns. (1) and (2), we get

$$P_a (2 + 1.111) = 250$$

$$\therefore P_a = 80.36 \text{ kN}$$

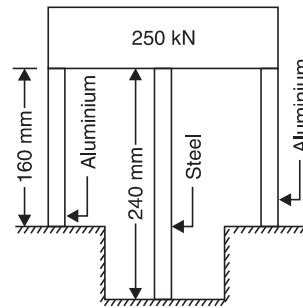
Hence from eqn. (1),

$$P_s = 250 - 2 \times 80.36 = 89.28 \text{ kN}$$

$\therefore$  Stresses developed are

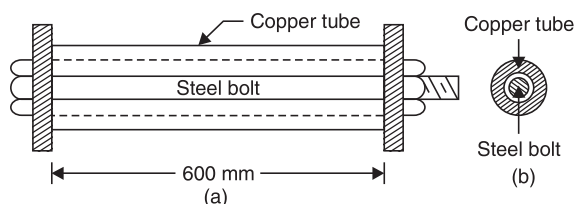
$$\sigma_s = \frac{P_s}{A_s} = \frac{89.28 \times 1000}{1000} = 89.28 \text{ N/mm}^2$$

$$\sigma_a = \frac{80.36 \times 1000}{1200} = 66.97 \text{ N/mm}^2$$



**Fig. 38**

**Example 14.** A steel bolt of 20 mm diameter passes centrally through a copper tube of internal diameter 28 mm and external diameter 40 mm. The length of whole assembly is 600 mm. After tight fitting of the assembly, the nut is over tightened by quarter of a turn. What are the stresses introduced in the bolt and tube, if pitch of nut is 2 mm? Take  $E_s = 2 \times 10^5 \text{ N/mm}^2$  and  $E_c = 1.2 \times 10^5 \text{ N/mm}^2$ .



**Fig. 39**



**Solution:** Figure 8.40 shows the assembly. Let the force shared by bolt be  $P_s$  and that by tube be  $P_c$ . Since there is no external force, static equilibrium condition gives

$$P_s + P_c = 0 \quad \text{or} \quad P_s = -P_c$$

*i.e.*, the two forces are equal in magnitude but opposite in nature. Obviously bolt is in tension and tube is in compression.

Let the magnitude of force be  $P$ . Due to quarter turn of the nut, the nut advances by  $\frac{1}{4} \times \text{pitch}$   
 $= \frac{1}{4} \times 2 = 0.5 \text{ mm}$ .

[**Note.** Pitch means advancement of nut in one full turn]

During this process bolt is extended and copper tube is shortened due to force  $P$  developed. Let  $\Delta_s$  be extension of bolt and  $\Delta_c$  shortening of copper tube. Final position of assembly be  $\Delta$ , then

$$\Delta_s + \Delta_c = \Delta$$

*i.e.* 
$$\frac{P_s L_s}{A_s E_s} + \frac{P_c L_c}{A_c E_c} = 0.5$$

$$\frac{P \times 600}{(\pi/4) \times 20^2 \times 2 \times 10^5} + \frac{P \times 600}{(\pi/4) (40^2 - 28^2) \times 1.2 \times 10^5} = 0.5$$

$$\frac{P \times 600}{(\pi/4) \times 10^5} \left[ \frac{1}{20^2 \times 2} + \frac{1}{(40^2 - 28^2) \times 1.2} \right] = 0.5$$

$\therefore P = 28816.8 \text{ N}$

$\therefore p_s = \frac{P_s}{A_s} = \frac{28816.8}{(\pi/4) \times 20^2} = 91.72 \text{ N/mm}^2$

$$p_c = \frac{P_c}{A_c} = \frac{28816.8}{(\pi/4) (40^2 - 28^2)} = 44.96 \text{ N/mm}^2$$



## THERMAL STRESSES

Every material expands when temperature rises and contracts when temperature falls. It is established experimentally that the change in length  $\Delta$  is directly proportional to the length of the member  $L$  and change in temperature  $t$ . Thus

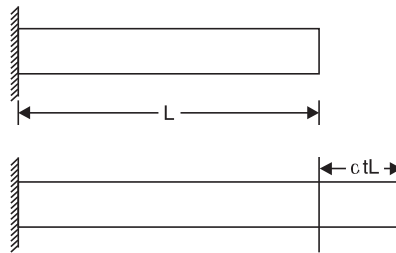
$$\begin{aligned}\Delta &\propto tL \\ &= \alpha tL\end{aligned}\quad \dots(8.25)$$

The constant of proportionality  $\alpha$  is called coefficient of thermal expansion and is defined as change in unit length of material due to unit change in temperature. Table 8.1 shows coefficient of thermal expansion for some of the commonly used engineering materials:

**Table 1**

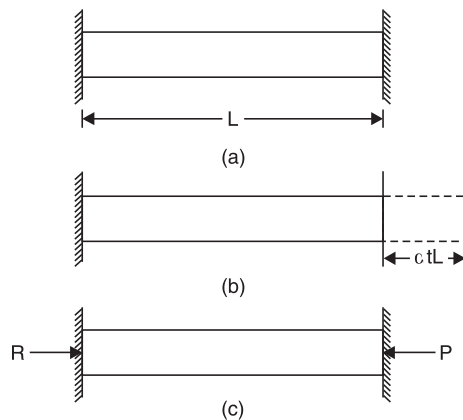
Material	Coefficient of thermal expansion
Steel	$12 \times 10^{-6}/^{\circ}\text{C}$
Copper	$17.5 \times 10^{-6}/^{\circ}\text{C}$
Stainless steel	$18 \times 10^{-6}/^{\circ}\text{C}$
Brass, Bronze	$19 \times 10^{-6}/^{\circ}\text{C}$
Aluminium	$23 \times 10^{-6}/^{\circ}\text{C}$

If the expansion of the member is freely permitted, as shown in Fig. 8.41, no temperature stresses are induced in the material.



**Fig. 40** Free Expansion Permitted

If the free expansion is prevented fully or partially the stresses are induced in the bar, by the support forces. Referring to Fig. 41,



**Fig. 41**

If free expansion is permitted the bar would have expanded by

$$\Delta = \alpha tL$$

Since support is not permitting it, the support force  $P$  develops to keep it at the original position. Magnitude of this force is such that contraction is equal to free expansion, *i.e.*

$$\frac{PL}{AE} = \alpha tL$$

or

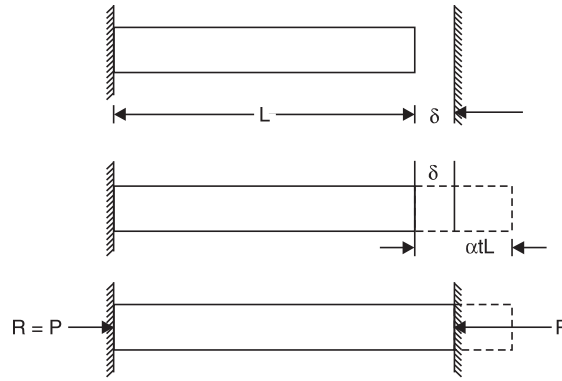
$$p = E \alpha t. \quad \dots(26)$$

$p$  is compressive in nature in this case.





Consider the case shown in Fig. 8.43 in which free expansion is prevented partially.



**Fig. 42**

In this case free expansion =  $\alpha tL$   
 Expansion prevented  $\Delta = \alpha tL - \delta$

The expansion is prevented by developing compressive force  $P$  at supports

$$\therefore \frac{PL}{AE} = \Delta = \alpha tL - \delta. \quad \dots(27)$$

**Example 15.** A steel rail is 12 m long and is laid at a temperature of 18°C. The maximum temperature expected is 40°C.

- (i) Estimate the minimum gap between two rails to be left so that the temperature stresses do not develop.
- (ii) Calculate the temperature stresses developed in the rails, if:
  - (a) No expansion joint is provided.
  - (b) If a 1.5 mm gap is provided for expansion.
- (iii) If the stress developed is 20 N/mm<sup>2</sup>, what is the gap provided between the rails?  
 Take  $E = 2 \times 10^5$  N/mm<sup>2</sup> and  $\alpha = 12 \times 10^{-6}/^\circ\text{C}$ .

**Solution:**

- (i) The free expansion of the rails

$$\begin{aligned} &= \alpha tL = 12 \times 10^{-6} \times (40 - 18) \times 12.0 \times 1000 \\ &= 3.168 \text{ mm} \end{aligned}$$

**$\therefore$  Provide a minimum gap of 3.168 mm between the rails, so that temperature stresses do not develop.**

- (ii) (a) If no expansion joint is provided, free expansion prevented is equal to 3.168 mm.

i.e.  $\Delta = 3.168 \text{ mm}$

$$\therefore \frac{PL}{AE} = 3.168$$

$$\therefore p = \frac{P}{A} = \frac{3.168 \times 2 \times 10^5}{12 \times 1000} = 52.8 \text{ N/mm}^2$$

- (b) If a gap of 1.5 mm is provided, free expansion prevented  $\Delta = \alpha tL - \delta = 3.168 - 1.5 = 1.668 \text{ mm}$ .

$\therefore$  The compressive force developed is given by  $\frac{PL}{AE} = 1.668$

or 
$$p = \frac{P}{A} = \frac{1.668 \times 2 \times 10^5}{12 \times 1000} = 27.8 \text{ N/mm}^2$$



(iii) If the stress developed is  $20 \text{ N/mm}^2$ , then  $p = \frac{P}{A} = 20$

If  $\delta$  is the gap,  $\Delta = \alpha tL - \delta$

$$\therefore \frac{PL}{AE} = 3.168 - \delta$$

i.e.  $20 \times \frac{12 \times 1000}{2 \times 10^5} = 3.168 - \delta$

$$\therefore \delta = 3.168 - 1.20 = \mathbf{1.968 \text{ mm}}$$

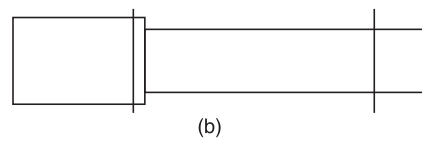
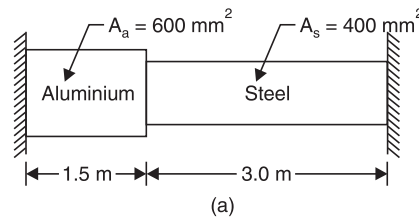
**Example 16.** The composite bar shown in Fig. 43 is rigidly fixed at the ends A and B. Determine the reaction developed at ends when the temperature is raised by  $18^\circ\text{C}$ . Given

$$E_a = 70 \text{ kN/mm}^2$$

$$E_s = 200 \text{ kN/mm}^2$$

$$\alpha_a = 11 \times 10^{-6}/^\circ\text{C}$$

$$\alpha_s = 12 \times 10^{-6}/^\circ\text{C}$$



**Fig.43**

**Solution:** Free expansion =  $\alpha_a tL_a + \alpha_s tL_s$   
 $= 11 \times 10^{-6} \times 18 \times 1500 + 12 \times 10^{-6} \times 18 \times 3000$   
 $= 0.945 \text{ mm}$

Since this is prevented

$$\Delta = 0.945 \text{ mm.}$$

$$E_a = 70 \text{ kN/mm}^2 = 70000 \text{ N/mm}^2 ;$$

$$E_s = 200 \text{ kN/mm}^2 = 200 \times 1000 \text{ N/mm}^2$$

If  $P$  is the support reaction,

$$\Delta = \frac{PL_a}{A_a E_a} + \frac{PL_s}{A_s E_s}$$

i.e.  $0.945 = P \left[ \frac{1500}{600 \times 70000} + \frac{3000}{400 \times 200 \times 1000} \right]$

$$0.945 = 73.214 \times 10^{-6} P$$

or  $P = \mathbf{12907.3 \text{ N}}$



## THERMAL STRESSES IN COMPOUND BARS

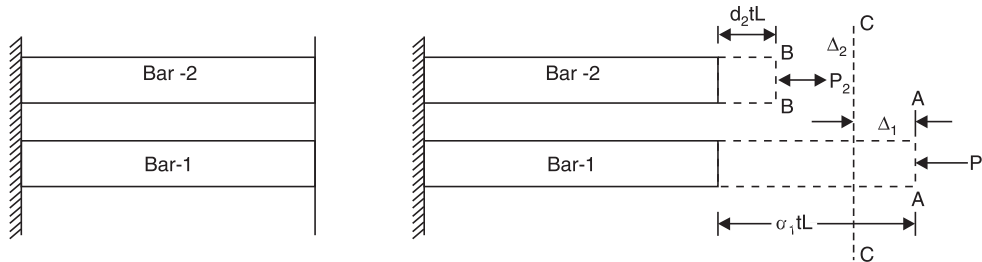
When temperature rises the two materials of the compound bar experience different free expansion. Since they are prevented from separating, the two bars will have common position. This is possible only by extension of the bar which has less free expansion and contraction of the bar which has more free expansion. Thus one bar develops tensile force and another develops the compressive force. In this article we are interested to find such stresses.

Consider the compound bar shown in Fig. 45(a). Let  $\alpha_1, \alpha_2$  be coefficient of thermal expansion and  $E_1, E_2$  be moduli of elasticity of the two materials respectively. If rise in temperature is 't',

$$\text{Free expansion of bar 1} = \alpha_1 tL$$

$$\text{Free expansion of bar 2} = \alpha_2 tL$$

Let  $\alpha_1 > \alpha_2$ . Hence the position of the two bars, if the free expansions are permitted are at AA and BB as shown in Fig.



**Fig. 45**

Since the two bars are rigidly connected at the ends, the final position of the end will be somewhere between AA and BB, say at CC. It means Bar-1 will experience compressive force  $P_1$  which contracts it by  $\Delta_1$  and Bar-2 experience tensile force  $P_2$  which will expand it by  $\Delta_2$ .

The equilibrium of horizontal forces gives,

$$P_1 = P_2, \text{ say } P$$

From the Fig. 8.46 (b), it is clear,

$$\alpha_1 tL - \Delta_1 = \alpha_2 tL + \Delta_2$$

$$\therefore \Delta_1 + \Delta_2 = \alpha_1 tL - \alpha_2 tL = (\alpha_1 - \alpha_2) tL.$$

If the cross-sectional areas of the bars are  $A_1$  and  $A_2$ , we get

$$\frac{PL}{A_1 E_1} + \frac{PL}{A_2 E_2} = (\alpha_1 - \alpha_2) t L \quad \dots(8.28)$$

From the above equation force  $P$  can be found and hence the stresses  $P_1$  and  $P_2$  can be determined.



**Example 17.** A bar of brass 20 mm is enclosed in a steel tube of 40 mm external diameter and 20 mm internal diameter. The bar and the tubes are initially 1.2 m long and are rigidly fastened at both ends using 20 mm diameter pins. If the temperature is raised by 60°C, find the stresses induced in the bar, tube and pins.

Given:

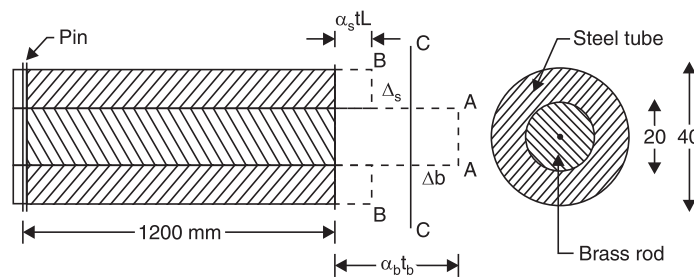
$$E_s = 2 \times 10^5 \text{ N/mm}^2$$

$$E_b = 1 \times 10^5 \text{ N/mm}^2$$

$$\alpha_s = 11.6 \times 10^{-6}/^\circ\text{C}$$

$$\alpha_b = 18.7 \times 10^{-6}/^\circ\text{C}.$$

**Solution:**



**Fig. 46**

$$t = 60^\circ \quad E_s = 2 \times 10^5 \text{ N/mm}^2 \quad E_b = 1 \times 10^5 \text{ N/mm}^2$$

$$\alpha_s = 11.6 \times 10^{-6}/^\circ\text{C} \quad \alpha_b = 18.7 \times 10^{-6}/^\circ\text{C}$$

$$A_s = \frac{\pi}{4} (40^2 - 20^2) \quad A_b = \frac{\pi}{4} \times 20^2$$

$$= 942.48 \text{ mm}^2 \quad = 314.16 \text{ mm}^2$$

Since free expansion of brass ( $\alpha_b tL$ ) is more than free expansion of steel ( $\alpha_s tL$ ), compressive force  $P_b$  develops in brass and tensile force  $P_s$  develops in steel to keep the final position at CC (Ref: Fig. 46).

Horizontal equilibrium condition gives  $P_b = P_s$ , say  $P$ . From the figure, it is clear that

$$\Delta_s + \Delta_b = \alpha_b tL - \alpha_s tL = (\alpha_b - \alpha_s)tL.$$

where  $\Delta_s$  and  $\Delta_b$  are the changes in length of steels and brass bars.

$$\therefore \frac{PL}{A_s E_s} + \frac{PL}{A_b E_b} = (18.7 - 11.6) \times 10^{-6} \times 60 \times 1200.$$

$$P \times 1200 \left[ \frac{1}{942.48 \times 2 \times 10^5} + \frac{1}{314.16 \times 1 \times 10^5} \right] = 7.1 \times 10^{-6} \times 60 \times 1200$$

$$\therefore P = 11471.3 \text{ N}$$

$$\therefore \text{Stress in steel} = \frac{P}{A_s} = \frac{11471.3}{942.48} = 12.17 \text{ N/mm}^2$$

and 
$$\text{Stress in brass} = \frac{P}{A_b} = \frac{11471.3}{314.16} = 36.51 \text{ N/mm}^2$$

The pin resist the force  $P$  at the two cross-sections at junction of two bars.

$$\therefore \text{Shear stress in pin} = \frac{P}{2 \times \text{Area of pin}}$$

$$= \frac{11471.3}{2 \times \pi/4 \times 20^2} = 18.26 \text{ N/mm}^2$$



## IMPORTANT FORMULAE

1. If stress is uniform

$$p = \frac{P}{A}$$

2. (i) Linear strain =  $\frac{\text{Change in length}}{\text{Original length}}$

(ii) Lateral strain =  $\frac{\text{Change in lateral dimension}}{\text{Original lateral dimension}}$

3. Poisson's ratio =  $\frac{\text{Lateral strain}}{\text{Linear strain}}$ , within elastic limit.

4. Percentage elongation =  $\frac{L' - L}{L} \times 100$ .

5. Percentage reduction in area =  $\frac{A - A'}{A} \times 100$ .

6. Nominal stress =  $\frac{\text{Load}}{\text{Original cross-sectional area}}$ .

7. True stress =  $\frac{\text{Load}}{\text{Actual cross-sectional area}}$ .

8. Factor of safety =  $\frac{\text{Ultimate stress}}{\text{Working stress}}$

However in case of steel, =  $\frac{\text{Yield stress}}{\text{Working stress}}$ .

9. Hooke's Law,  $p = Ee$ .

10. Extension/shortening of bar =  $\frac{PL}{AE}$ .

11. Extension of flat bar with linearly varying width and constant thickness =  $\frac{PL}{tE(b_1 - b_2)} \log \frac{b_1}{b_2}$ .

12. Extension of linearly tapering rod =  $\frac{4PL}{\pi E d_1 d_2} = \frac{PL}{(\pi/4 d_1 d_2) E}$ .

13. Direct shear stress =  $\frac{Q}{A}$ .

14. Volumetric strain  $e_v = \frac{\delta V}{V} = e_x + e_y + e_z$ .

15.  $E = 2G(1 + \mu) = 3K(1 - 2\mu)$

or  $\frac{9}{E} = \frac{3}{G} + \frac{1}{K}$ .

16. Extension due to rise in temperature:

$$\Delta = \alpha tL$$

17. Thermal force,  $P$  is given by

$$\frac{PL}{AE} = \text{extension prevented.}$$



# Tutorial questions

1. Draw stress strain diagram for ductile materials and indicate all salient features on it. Explain the various mechanical properties can be estimated from that diagram.
2. Derive the relations between E,G,K
3. Derive the expression for the elongation for the circular tapered bar
4. Two parallel walls 6m apart are stayed together by a 25 mm diameter steel rod at 80°C passing through washers and nuts at ends. If the rod cools down to 22°C, calculate the pull induced in the rod, if
  - (a) the walls do not yield and
  - (b) the total yield at ends is 1.5 mm $E_{\text{steel}} = 2 \times 10^5 \text{ N/mm}^2$ ,  $\alpha_{\text{steel}} = 11 \times 10^{-6} \text{ per}^\circ\text{C}$ .
5. A) A metallic rod of 1 cm diameter, when tested under an axial pull of 10 kN was found to reduce its diameter by 0.0003 cm. The modulus of rigidity for the rod is 51 KN/mm<sup>2</sup>. Find the Poisson's ratio, modulus of elasticity and Bulk Modulus.  
  
b) An aluminium bar 60 mm diameter when subjected to an axial tensile load 100 kN elongates 0.20 mm in a gage length 300 mm and the diameter is decreased by 0.012 mm. Calculate the modulus of elasticity and the Poisson's ratio of the material.
6. A specimen of diameter 13 mm and gauge length 50 mm was tested under tension. At 20 kN load, the extension was observed to be 0.0315 mm. Yielding occurred at a load of 35 kN and the ultimate load was 60 KN. The final gauge length at fracture was 70 mm. Calculate young's modulus, yield stress, ultimate strength and percentage elongation.



# Assignment Questions

1. Determine the young's modulus and Possion's ratio of a metallic bar of length 25cm breadth 3cm depth 2cm when the beam is subjected to an axial compressive load 240KN. The decrease in length is given by 0.05cm and increase in breadth 0.002
2. Write the differences among Gradual, Sudden, Impact and Shock loadings with the help of expressions
3. A steel rod and two copper rods together support a load of 370 kN as shown in fig. The cross sectional area of steel rod is  $2500 \text{ mm}^2$  and of each copper rod is  $1600 \text{ mm}^2$ . Find the stresses in the rods. Take E for steel is  $2 \times 10^5 \text{ N/mm}^2$  and for copper is  $1 \times 10^5 \text{ N/mm}^2$
4. A vertical tie, fixed rigidly at the top end consist of a steel rod 2.5 m long and 20 mm diameter encased throughout in a brass tube 20 mm internal diameter and 30 mm external diameter. The rod and the casing are fixed together at both ends. The compound rod is loaded in tension by a force of 10 kN. Calculate the maximum stress in steel and brass. Take  $E_s = 2 \times 10^5 \text{ N/mm}^2$  and  $E_b = 1 \times 10^5 \text{ N/mm}^2$
5. A steel tube 50mm in external diameter and 3mm thick encloses centrally a solid copper bar of 35mm diameter. The bar and the tube are rigidly connected together at the ends at a temperature of  $20^\circ\text{C}$ . Find the stress in each metal when heated to  $170^\circ\text{C}$ . Also find the increase in length, if the original length of the assembly is 350mm. Take  $\alpha_s = 1.08 \times 10^{-5} \text{ per } ^\circ\text{C}$  and  $\alpha_c = 1.7 \times 10^{-5} \text{ per } ^\circ\text{C}$ . Take  $E_s = 2 \times 10^5 \text{ N/mm}^2$ ,  $E_c = 1 \times 10^5 \text{ N/mm}^2$



---

**UNIT 2**

**SHEAR FORCE & BENDING  
MOMENT DIAGRAMS**

---



**Course Objectives:**

- To plot the variation of shear force and bending moments over the beams under different types of loads.

**Course Outcomes:**

- Draw the shear force and bending moment diagrams for the beam subjected to different loading conditions.

## UNIT II

### SHEAR FORCE AND BENDING MOMENT DIAGRAMS

#### Shear force

The algebraic sum of the vertical forces at any section of a beam to the right or left of the section is known as shear force

#### Bending moment

The algebraic sum of the moments of all the forces acting to the right or left of the section is known as bending moment

#### Shear force and bending moment diagrams

A shear force diagram is one which shows the variation of the shear force along the length of the beam. And a bending moment diagram is one which shows the variation of the bending moment along the length of the beam.

#### Important points for Shear force and bending moment

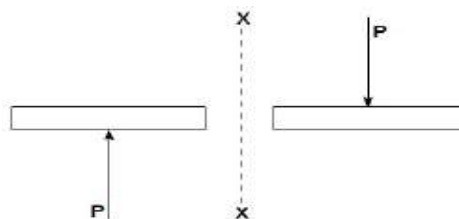
1. Shear Force ( $V$ )  $\equiv$  equal in magnitude but opposite in direction to the algebraic sum (resultant) of the components in the direction perpendicular to the axis of the beam of all external loads and support reactions acting on either side of the section being considered.
2. Bending Moment ( $M$ ) equal in magnitude but opposite in direction to the algebraic sum of the moments about (the centroid of the cross section of the beam) the section of all external loads and support reactions acting on either side of the section being considered.

#### Notation and sign convention

##### 1. Shear force ( $V$ )

Positive Shear Force

A shearing force having a downward direction to the right hand side of a section or upwards to the left hand of the section will be taken as 'positive'. It is the usual sign conventions to be followed for the shear force. In some book followed totally opposite sign convention.



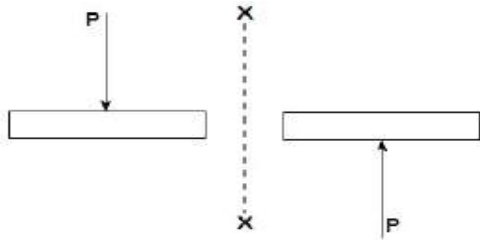
The **upward direction** shearing force which is on the left hand of the section XX is positive shear force



The **downward direction** shearing force which is on the right hand of the section XX is positive shear force.

### Negative Shear Force

A shearing force having an upward direction to the right hand side of a section or downwards to the left hand of the section will be taken as 'negative'.



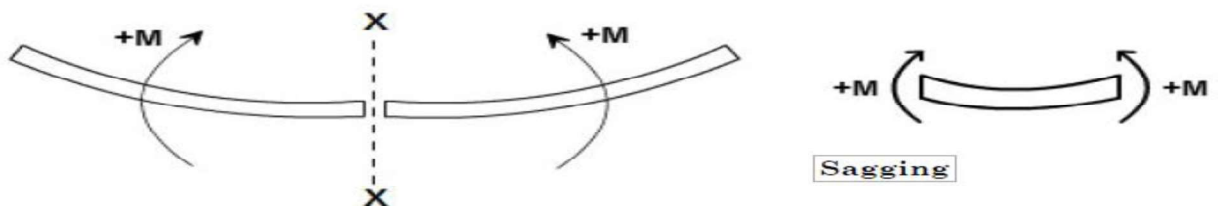
The downward direction shearing force which is on the left hand of the section XX is negative shear force.

The upward direction shearing force which is on the right hand of the section XX is negative shear force.

### Bending Moment (M)

#### Positive Bending Moment

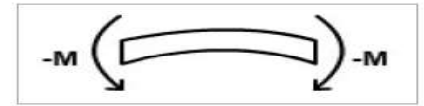
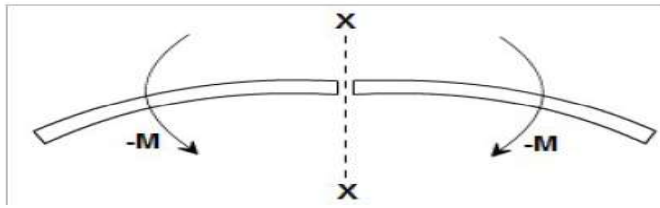
A bending moment causing concavity upwards will be taken as 'positive' and called as sagging bending moment.



- If the bending moment of the left hand of the section XX is clockwise then it is a positive bending moment.
- If the bending moment of the right hand of the section XX is anti-clockwise then it is a positive bending moment.
- A bending moment causing concavity upwards will be taken as 'positive' and called as sagging bending moment

#### Negative Bending Moment





Hogging

- If the bending moment of the left hand of the section XX is anti-clockwise then it is a negative bending moment.
- If the bending moment of the right hand of the section XX is clockwise then it is a negative bending moment.
- **Hogging**  
A bending moment causing convexity upwards will be taken as 'negative' and called as hogging bending moment.

### Relation between S.F ( $V_x$ ), B.M. ( $M_x$ ) & Load ( $w$ )

$$\frac{dV_x}{dx} = -w \text{ (load)}$$

The value of the distributed load at any point in the beam is equal to the slope of the shear force curve. (Note that the sign of this rule may change depending on the sign convention used for the external distributed load).

$$\frac{dM_x}{dx} = V_x$$

The value of the shear force at any point in the beam is equal to the slope of the bending moment curve.

### Procedure for drawing shear force and bending moment diagram

#### Construction of shear force diagram

- From the loading diagram of the beam constructed shear force diagram.
- First determine the reactions.
- Then the vertical components of forces and reactions are successively summed from the left end of the beam to preserve the mathematical sign conventions adopted. The shear at a section is simply equal to the sum of all the vertical forces to the left of the section.
- The shear force curve is continuous unless there is a point force on the beam. The curve then "jumps" by the magnitude of the point force (+ for upward force).
- When the successive summation process is used, the shear force diagram should end up with the previously calculated shear (reaction at right end of the beam). No shear force acts through the beam just beyond the last vertical force or reaction. If the shear



force diagram closes in this fashion, then it gives an important check on mathematical calculations. i.e. The shear force will be zero at each end of the beam unless a point force is applied at the end.

### Construction of bending moment diagram

- The bending moment diagram is obtained by proceeding continuously along the length of beam from the left hand end and summing up the areas of shear force diagrams using proper sign convention.
- The process of obtaining the moment diagram from the shear force diagram by summation is exactly the same as that for drawing shear force diagram from load diagram.
- The bending moment curve is continuous unless there is a point moment on the beam. The curve then “jumps” by the magnitude of the point moment (+ for CW moment).
- We know that a constant shear force produces a uniform change in the bending moment, resulting in straight line in the moment diagram. If no shear force exists along a certain portion of a beam, then it indicates that there is no change in moment takes place. We also know that  $dM/dx = V$  therefore, from the fundamental theorem of calculus the maximum or minimum moment occurs where the shear is zero.
- The bending moment will be zero at each free or pinned end of the beam. If the end is built in, the moment computed by the summation must be equal to the one calculated initially for the reaction.

### A Cantilever beam with a concentrated load ‘P’ at its free end

#### Shear force:

At a section a distance  $x$  from free end consider the forces to the left, then

$$(V_x) = -P \text{ (for all values of } x) \text{ negative in sign}$$

i.e. the shear force to the left of the  $x$ -section are in downward direction and therefore negative.

Bending Moment:



### Bending Moment

Taking moments about the section gives (obviously to the left of the section)

$$M_x = -P.x$$

(negative sign means that the moment on the left hand side of the portion is in the anticlockwise direction and is therefore taken as negative according to the sign convention)

so that the maximum bending moment occurs at the fixed end i.e.

$$M_{\max} = -PL \text{ (at } x = L)$$

### A Cantilever beam with uniformly distributed load over the whole length

When a cantilever beam is subjected to a uniformly distributed load whose intensity is given  $w$  /unit length.

#### Shear force:

Consider any cross-section XX which is at a distance of  $x$  from the free end. If we just take the resultant of all the forces on the left of the X-section, then

$$V_x = -w.x \quad \text{for all values of 'x'.$$

$$\text{At } x = 0, \quad V_x = 0$$

$$\text{At } x = L, \quad V_x = -wL \text{ (i.e. Maximum at fixed end)}$$

Plotting the equation  $V_x = -w.x$ , we get a straight line because it is a equation of a straight line  $y$

$$(V_x) = m(-w) .x$$

#### Bending Moment:

Bending Moment at XX is obtained by treating the load to the left of XX as a concentrated load of the same value ( $w.x$ ) acting through the centre of gravity at  $x/2$ .

Therefore, the bending moment at any cross-section XX is

$$M_x = (-w.x) \cdot \frac{x}{2} = -\frac{w.x^2}{2}$$

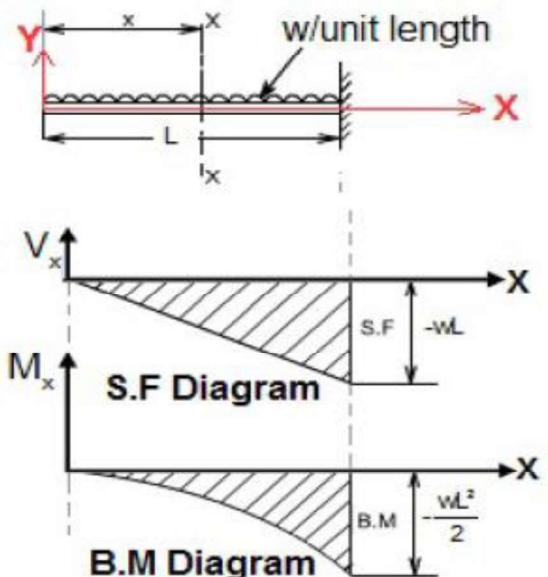
Therefore the variation of bending moment is according to parabolic law.

The extreme values of B.M would be

$$\text{at } x = 0, \quad M_x = 0$$

$$\text{and } x = L, \quad M_x = -\frac{wL^2}{2}$$

$$\text{Maximum bending moment, } M_{\max} = \frac{wL^2}{2} \text{ at fixed end}$$



S.F and B.M diagram



**A Cantilever beam loaded as shown below draw its S.F and B.M diagram**

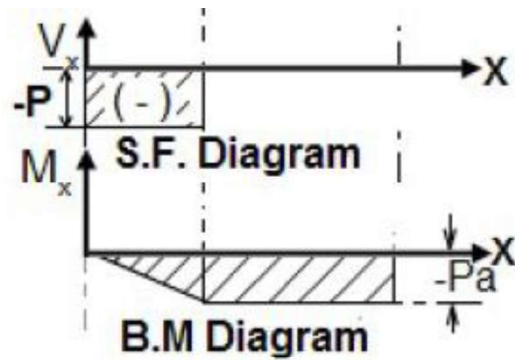
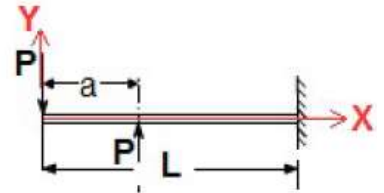
In the region  $0 < x < a$

Following the same rule as followed previously, we get

$$V_x = -P; \text{ and } M_x = -P.x$$

In the region  $a < x < L$

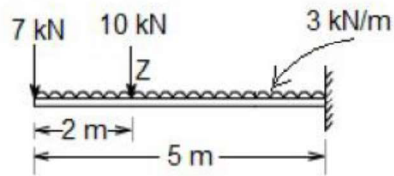
$$V_x = -P + P = 0; \text{ and } M_x = -P.x + P(x - a) = -P.a$$



**S.F and B.M diagram**

**Example 1:** A cantilever beam of 5 m length. It carries a uniformly distributed load 3 kN/m and a concentrated load of 7 kN at the free end and 10 kN at 3 meters from the fixed end.





Draw SF and BM diagram.

**Answer:** In the region  $0 < x < 2$  m

Consider any cross section XX at a distance  $x$  from free end.

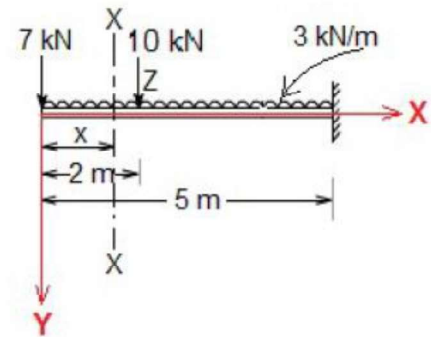
$$\text{Shear force } (V_x) = -7 - 3x$$

So, the variation of shear force is linear.

$$\text{at } x = 0, \quad V_x = -7 \text{ kN}$$

$$\text{at } x = 2 \text{ m}, \quad V_x = -7 - 3 \times 2 = -13 \text{ kN}$$

$$\text{at point Z} \quad V_x = -7 - 3 \times 2 - 10 = -23 \text{ kN}$$



$$\text{Bending moment } (M_x) = -7x - (3x) \cdot \frac{x}{2} = -\frac{3x^2}{2} - 7x$$

So, the variation of bending force is parabolic.

$$\text{at } x = 0, \quad M_x = 0$$

$$\text{at } x = 2 \text{ m}, \quad M_x = -7 \times 2 - (3 \times 2) \times \frac{2}{2} = -20 \text{ kNm}$$

**In the region  $2 \text{ m} < x < 5$  m**

Consider any cross section YY at a distance  $x$  from free end

$$\text{Shear force } (V_x) = -7 - 3x - 10 = -17 - 3x$$

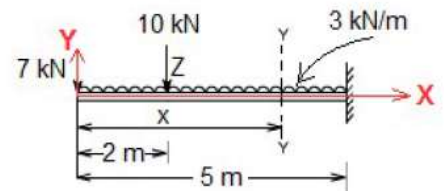
So, the variation of shear force is linear.

$$\text{at } x = 2 \text{ m}, \quad V_x = -23 \text{ kN}$$

$$\text{at } x = 5 \text{ m}, \quad V_x = -32 \text{ kN}$$

$$\text{Bending moment } (M_x) = -7x - (3x) \times \left(\frac{x}{2}\right) - 10(x - 2)$$

$$= -\frac{3}{2}x^2 - 17x + 20$$

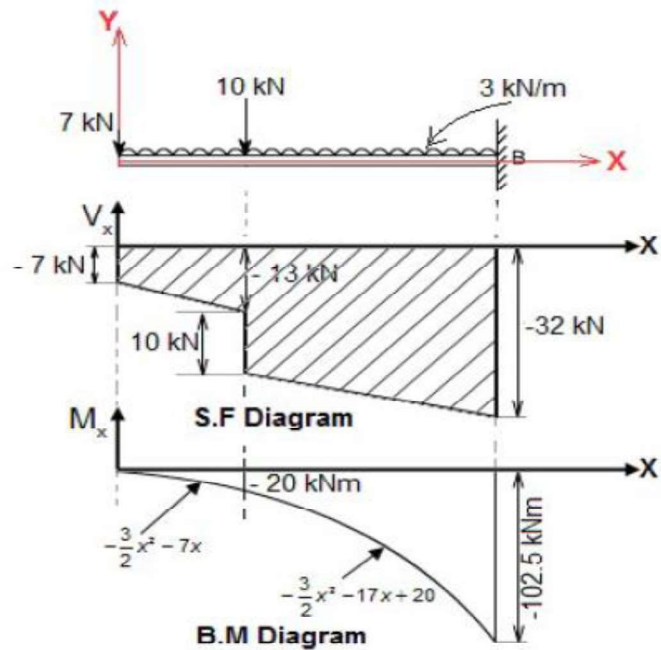




So, the variation of bending force is parabolic.

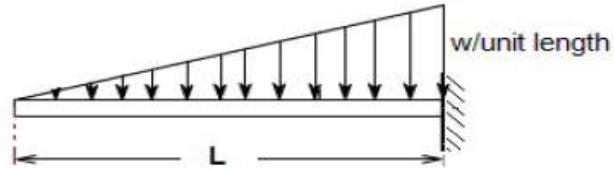
$$\text{at } x = 2 \text{ m, } M_x = -\frac{3}{2} \times 2^2 - 17 \times 2 + 20 = -20 \text{ kNm}$$

$$\text{at } x = 5 \text{ m, } M_x = -102.5 \text{ kNm}$$



**A Cantilever beam carrying uniformly varying load from zero at free end and  $w$ /unit length at the fixed end**





Consider any cross-section XX which is at a distance of  $x$  from the free end.

At this point load ( $w_x$ ) =  $\frac{W}{L} \cdot x$

Therefore total load ( $W$ ) =  $\int_0^L w_x dx = \int_0^L \frac{W}{L} \cdot x dx = \frac{WL}{2}$

**Shear force ( $V_x$ )** = area of ABC (load triangle)

$$= -\frac{1}{2} \cdot \left( \frac{w}{L} x \right) \cdot x = -\frac{wx^2}{2L}$$

∴ The shear force variation is parabolic.

at  $x = 0$ ,  $V_x = 0$

at  $x = L$ ,  $V_x = -\frac{WL}{2}$  i.e. Maximum Shear force ( $V_{max}$ ) =  $-\frac{WL}{2}$  at fixed end

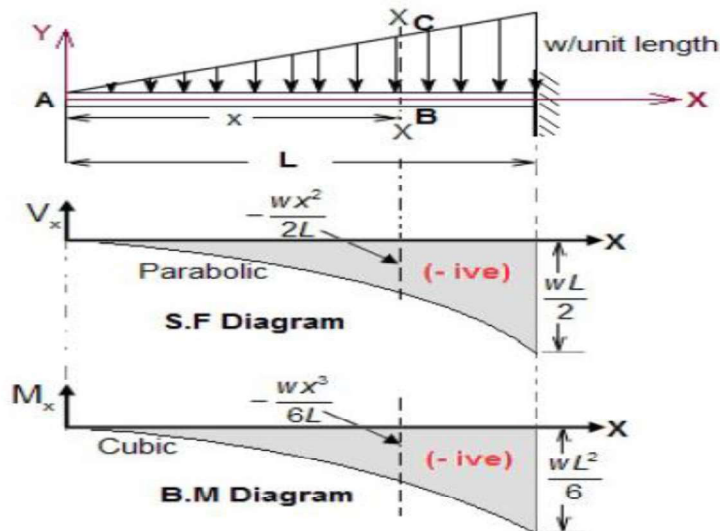
**Bending moment ( $M_x$ )** = load  $\times$  distance from centroid of triangle ABC

$$= -\frac{wx^2}{2L} \cdot \left( \frac{x}{3} \right) = -\frac{wx^3}{6L}$$

∴ The bending moment variation is cubic.

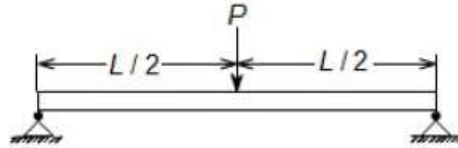
at  $x = 0$ ,  $M_x = 0$

at  $x = L$ ,  $M_x = -\frac{WL^2}{6}$  i.e. Maximum Bending moment ( $M_{max}$ ) =  $-\frac{WL^2}{6}$  at fixed end.



**A Simply supported beam with a concentrated load 'P' at its mid span**





Considering equilibrium we get,  $R_A = R_B = \frac{P}{2}$

Now consider any cross-section XX which is at a distance of  $x$  from left end A and section YY at a distance from left end A, as shown in figure below.

**Shear force:** In the region  $0 < x < L/2$

$$V_x = R_A = +P/2 \quad (\text{it is constant})$$

**In the region  $L/2 < x < L$**

$$V_x = R_A - P = \frac{P}{2} - P = -P/2 \quad (\text{it is constant})$$

**Bending moment:** In the region  $0 < x < L/2$

$$M_x = \frac{P}{2} \cdot x \quad (\text{its variation is linear})$$

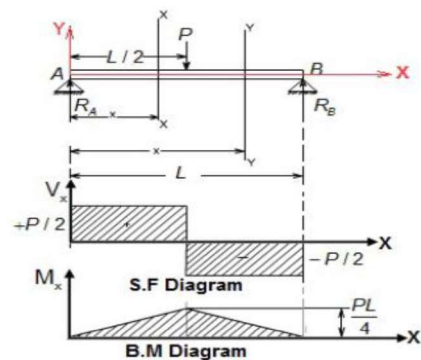
at  $x = 0$ ,  $M_x = 0$  and at  $x = L/2$   $M_x = \frac{PL}{4}$  i.e. maximum

Maximum bending moment,  $M_{\max} = \frac{PL}{4}$  at  $x = L/2$  (at mid-point)

**In the region  $L/2 < x < L$**

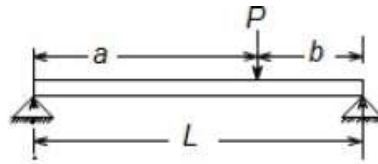
$$M_x = \frac{P}{2} \cdot x - P(x - L/2) = \frac{PL}{2} - \frac{P}{2} \cdot x \quad (\text{its variation is linear})$$

at  $x = L/2$ ,  $M_x = \frac{PL}{4}$  and at  $x = L$ ,  $M_x = 0$



**A Simply supported beam with a concentrated load 'P' is not at its mid span**





Considering equilibrium we get,  $R_A = \frac{Pb}{L}$  and  $R_B = \frac{Pa}{L}$

Now consider any cross-section XX which is at a distance  $x$  from left end A and another section YY at a distance  $x$  from end A as shown in figure below.

**Shear force: In the range  $0 < x < a$**

$$V_x = R_A = +\frac{Pb}{L} \quad (\text{it is constant})$$

**In the range  $a < x < L$**

$$V_x = R_A - P = -\frac{Pa}{L} \quad (\text{it is constant})$$

**Bending moment: In the range  $0 < x < a$**

$$M_x = +R_A x = \frac{Pb}{L} x \quad (\text{it is variation is linear})$$

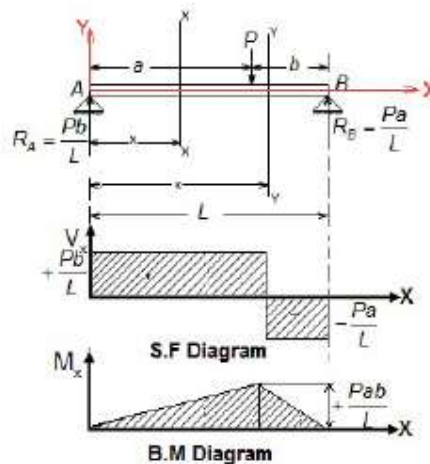
$$\text{at } x = 0, M_x = 0 \quad \text{and} \quad \text{at } x = a, M_x = \frac{Pab}{L} \quad (\text{i.e. maximum})$$

**In the range  $a < x < L$**

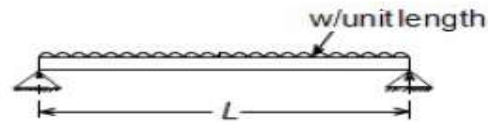
$$M_x = R_A x - P(x-a) = \frac{Pb}{L} x - Px + Pa \quad (\text{Put } b = L - a)$$

$$= Pa \left( 1 - Pa \left( 1 - \frac{x}{L} \right) \right)$$

$$\text{at } x = a, M_x = \frac{Pab}{L} \quad \text{and} \quad \text{at } x = L, M_x = 0$$



## A Simply supported beam with a uniformly distributed load (UDL) through out its length



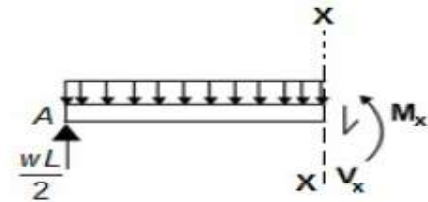
We will solve this problem by following two alternative ways.

### (a) By Method of Section

Considering equilibrium we get  $R_A = R_B = \frac{wL}{2}$

Now Consider any cross-section XX which is at a distance  $x$  from left end A.

Then the section view



$$\text{Shear force: } V_x = \frac{wL}{2} - wx$$

(i.e. S.F. variation is linear)

$$\text{at } x = 0, \quad V_x = \frac{wL}{2}$$

$$\text{at } x = L/2, \quad V_x = 0$$

$$\text{at } x = L, \quad V_x = -\frac{wL}{2}$$

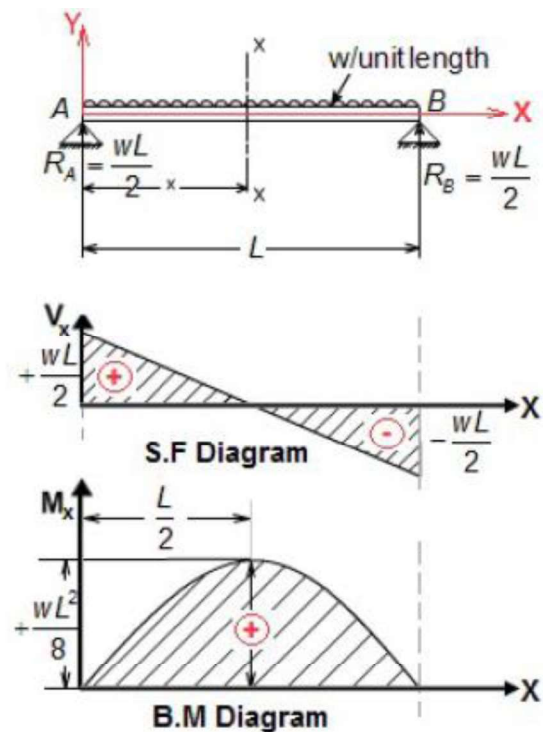
$$\text{Bending moment: } M_x = \frac{wL}{2} \cdot x - \frac{wx^2}{2}$$

(i.e. B.M. variation is parabolic)

$$\text{at } x = 0, \quad M_x = 0$$

$$\text{at } x = L, \quad M_x = 0$$

Now we have to determine maximum bending moment and its position.



$$\text{For maximum B.M.: } \frac{d(M_x)}{dx} = 0 \quad \text{i.e. } V_x = 0 \quad \left[ \because \frac{d(M_x)}{dx} = V_x \right]$$

$$\text{or } \frac{wL}{2} - wx = 0 \quad \text{or } x = \frac{L}{2}$$



Therefore, maximum bending moment,  $M_{\max} = \frac{wL^2}{8}$  at  $x = L/2$

(a) By Method of Integration

Shear force:

We know that,  $\frac{d(V_x)}{dx} = -w$

or  $d(V_x) = -w dx$

Integrating both side we get (at  $x=0$ ,  $V_x = \frac{wL}{2}$ )

$$\int_{\frac{wL}{2}}^{V_x} d(V_x) = -\int_0^x w dx$$

$$\text{or } V_x - \frac{wL}{2} = -wx$$

$$\text{or } V_x = \frac{wL}{2} - wx$$

Bending moment:

We know that,  $\frac{d(M_x)}{dx} = V_x$

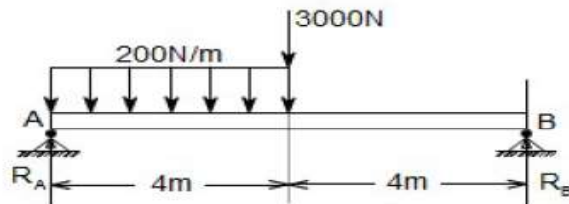
or  $d(M_x) = V_x dx = \left( \frac{wL}{2} - wx \right) dx$

Integrating both side we get (at  $x=0$ ,  $V_x = 0$ )

$$\int_0^{M_x} d(M_x) = \int_0^x \left( \frac{wL}{2} - wx \right) dx$$

$$\text{or } M_x = \frac{wL}{2} \cdot x - \frac{wx^2}{2}$$

**Example 2 :** A loaded beam as shown below. Draw its S.F and B.M diagram



Considering equilibrium we get

$$\sum M_A = 0 \text{ gives}$$

$$-(200 \times 4) \times 2 - 3000 \times 4 + R_B \times 8 = 0$$

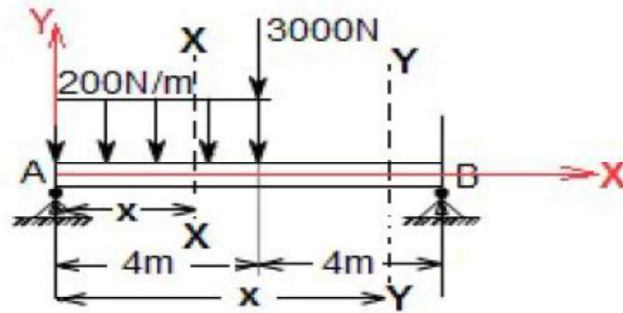
$$\text{or } R_B = 1700 \text{ N}$$

$$\text{And } R_A + R_B = 200 \times 4 + 3000$$

$$\text{or } R_A = 2100 \text{ N}$$

Now consider any cross-section XX which is at a distance 'x' from left end A and as shown in figure





In the region  $0 < x < 4\text{m}$

$$\text{Shear force } (V_x) = R_A - 200x = 2100 - 200x$$

$$\text{Bending moment } (M_x) = R_A \cdot x - 200x \cdot \left(\frac{x}{2}\right) = 2100x - 100x^2$$

$$\text{at } x = 0, \quad V_x = 2100 \text{ N}, \quad M_x = 0$$

$$\text{at } x = 4\text{m}, \quad V_x = 1300 \text{ N}, \quad M_x = 6800 \text{ N.m}$$

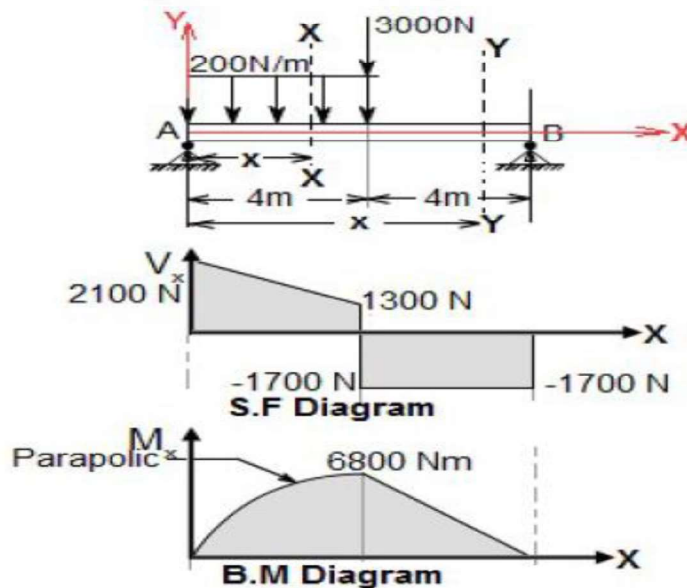
In the region  $4\text{m} < x < 8\text{m}$

$$\text{Shear force } (V_x) = R_A - 200 \times 4 - 3000 = -1700$$

$$\begin{aligned} \text{Bending moment } (M_x) &= R_A \cdot x - 200 \times 4(x-2) - 3000(x-4) \\ &= 2100x - 800x + 1600 - 3000x + 12000 = 13600 - 1700x \end{aligned}$$

$$\text{at } x = 4\text{m}, \quad V_x = -1700 \text{ N}, \quad M_x = 6800 \text{ Nm}$$

$$\text{at } x = 8\text{m}, \quad V_x = -1700 \text{ N}, \quad M_x = 0$$



## Shear force and bending moment diagrams for over-hanging beams

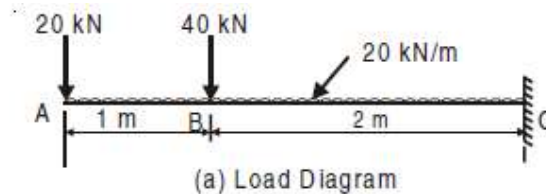
If the end portion of a beam is extended beyond the support, such beam is known as overhanging beam. In case of overhanging beams, the B.M. is positive between the two supports, whereas the S.F. is negative for the over-hanging portion. Hence at some point, the B.M. is zero after changing its sign from positive to negative or vice-versa. That point is known as the point of Contraflexure or point of inflexion

Point of Contraflexure:

It is the point where the B.M. is zero after changing its sign from positive to negative or vice-versa.

### Overhanging Beam Subjected to a Concentrated Load at Free End

Draw shear force and bending moment diagram for the cantilever beam shown in Fig.



**Solution:** Portion AB:

At distance  $x$ , from A,

$$F = -20 - 20x, \text{ linear variation.}$$

At  $x = 0$ ,  $F_A = -20 \text{ kN}$

At  $x = 1$ ,  $F_B = -20 - 20 \times 1 = -40 \text{ kN.}$

$$M = -20x - 20x \cdot \frac{x}{2}, \text{ parabolic variation}$$

At  $x = 0$ ,  $M_A = 0$

At  $x = 1 \text{ m}$ ,  $M_B = -20 - 20 \times 1 \times \frac{1}{2} = -30 \text{ kN-m.}$

Portion BC:

Measuring  $x$  from A,

$$F = -20 - 40 - 20x, \text{ linear variation.}$$

At  $x = 1 \text{ m}$ ,  $F_B = -80 \text{ kN}$

At  $x = 3 \text{ m}$ ,  $F_C = -120 \text{ kN.}$

$$M = -20x - 40(x - 1) - 20x \cdot \frac{x}{2}, \text{ parabolic variation;}$$

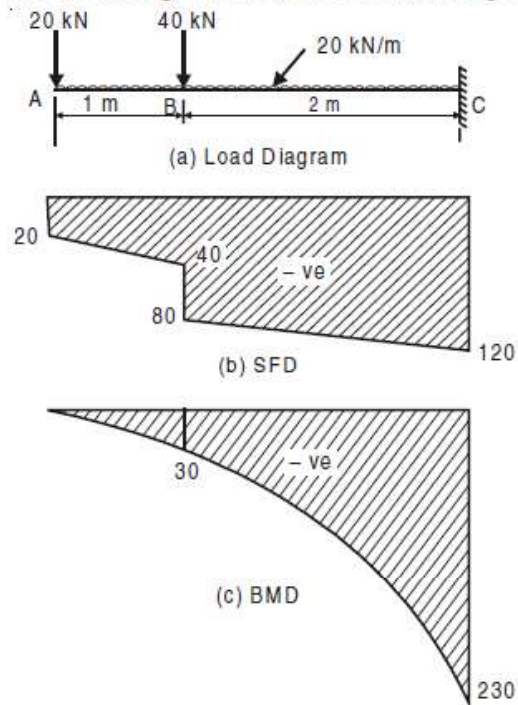
At  $x = 1 \text{ m}$ ,  $M = -30 \text{ kN-m}$

At  $x = 3 \text{ m}$ ,  $M = -60 - 40 \times 2 - 20 \times 3 \times \frac{3}{2}$   
 $= -230 \text{ kN-m}$





Hence *SFD* and *BMD* are shown in Fig. 9.37(b) and 9.37(c) respectively.



### Statically determinate & Statically Indeterminate beams

Beams for which reaction forces and internal forces cannot be found out from static equilibrium equations alone are called statically indeterminate beam. This type of beam requires deformation equation in addition to static equilibrium equations to solve for unknown forces.

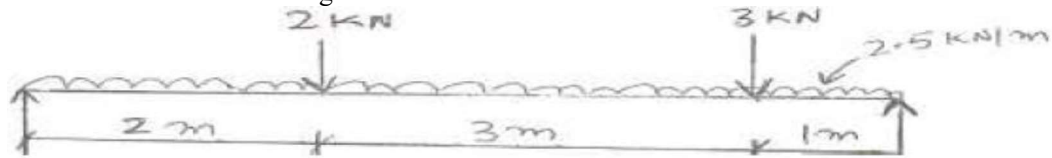
Statically determinate - Equilibrium conditions sufficient to compute reactions.

Statically indeterminate - Deflections (Compatibility conditions) along with equilibrium equations should be used to find out reactions.

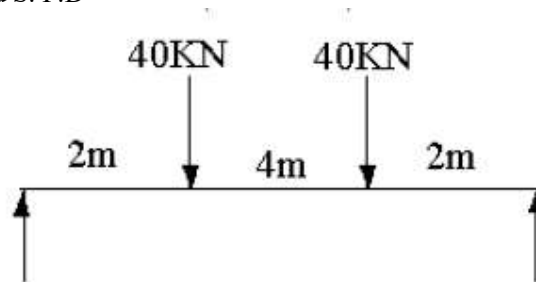


# Tutorial Questions

1. A cantilever of length 2.0 m carries a uniformly distributed load of 1 kN/m run over a length of 1.5 m from the free end. Draw the shear force and bending moment diagrams for the cantilever.
2. An overhanging beam ABC of length 7 m is simply supported at A and B over a span of 5 m and portion BC overhangs by 2 m. Draw the shearing force and bending moment diagrams and determine the point of contra-flexure if it is subjected to uniformly distributed loads of 3 kN/m over the portion AB and a concentrated load of 8 kN at C.
3. A beam of span 10m is simply supported at two points 6m apart with equal over-hang on either side. Both the overhanging portions are loaded with a uniformly distributed load of 2 kN/m run and the beam also carries a concentrated load of 10 N at the midspan. Construct the SF and BM diagrams and locate the points of inflexion, if any.
4. Sketch the shear force and bending moment diagrams showing the salient values for the loaded beam shown in the figure below.



5. A Simply supported beam of span, 9 m hL of 15 kN/m over 4 m from the left support and a concentrated load of 20kN at the center. Draw SF and BM diagrams
6. A Beam of length 12m is supported at left end and the other support is at a distance of 8m from the left support leaving a overhanging length of 4m on the right side. It carries a UDL of 10 kN/m over the entire length and a concentrated load of 8 kN at the right extreme end. Draw the shear force and bending moment diagrams and find the position of Contra flexure point
7. Draw the B. M. D and S. F. D



# Assignment Questions

1. A cantilever beam of 2 m long carries a uniformly distributed load of 1.5kN/m over a length of 1.6 m from the free end. Draw shear force and bending moment diagrams for the beam
2. A simply supported beam 6 m long is carrying a uniformly distributed load of 5kN/m over a length of 3 m from the right end. Draw shear force and bending moment diagrams for the beam and also calculate the maximum bending moment on the beam
3. A simply supported beam of 16m long carries the point loads of 4kN, 5kN and 3kN at distances 3m, 7m and 10m respectively from the left support. Calculate the maximum shear force and bending moment. Draw the SFD and BMD.
4. A horizontal beam of 10m long is carrying a uniformly distributed load of 1kN/m. The beam is supported on two supports 6m apart. Find the position of supports, so that bending moment on the beam is small as possible. Also draw the SFD & BMD for the beam
5. A beam of length  $l$  carries a uniformly distributed load of  $w$  per unit length. The beam is supported on two supports at equal distances from the two ends. Determine the position of the supports, if the B.M. to which the beam is subjected to, is as small as possible. Draw the SFD & BMD for the beam.
6. A simply supported beam of length 10m, carries the uniformly distributed load and two point loads as shown in Fig.(2) Draw the S.F and B.M diagram for the beam and also calculate the Maximum bending moment

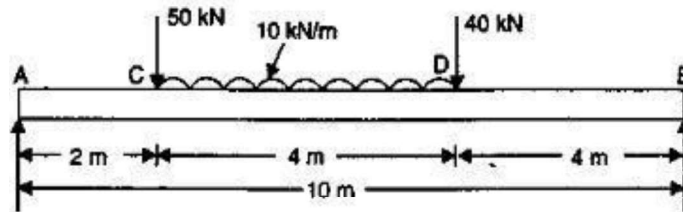


Fig.(2)



---

# **UNIT 3**

## **FLEXURAL & SHEAR STRESSES**

---

**Course Objectives:**

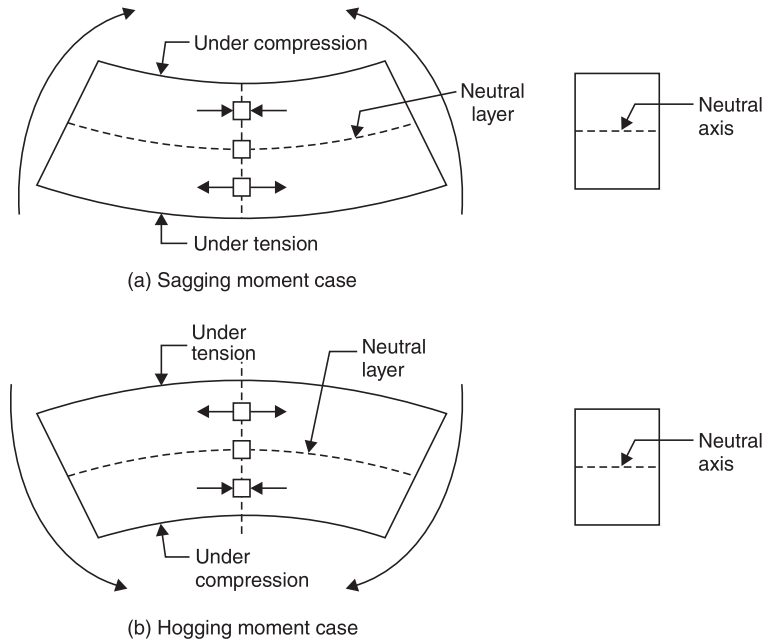
- To understand the behavior of beams subjected to shear loads.

**Course Outcomes:**

- Evaluate stresses induced in different cross-sectional members subjected to shear loads.

# Stresses in Beams

As seen in the last chapter beams are subjected to bending moment and shear forces which vary from section to section. To resist them stresses will develop in the materials of the beam. For the simplicity in analysis, we consider the stresses due to bending and stresses due to shear separately.



**Fig. 1.** Nature of Stresses in Beams

Due to pure bending, beams sag or hog depending upon the nature of bending moment as shown in Fig. 10.1. It can be easily observed that when beams sag, fibres in the bottom side get stretched while fibres on the top side are compressed. In other words, the material of the beam is subjected to tensile stresses in the bottom side and to compressive stresses in the upper side. In case of hogging the nature of bending stress is exactly opposite, *i.e.*, tension at top and compression at bottom. Thus bending stress varies from compression at one edge to tension at the other edge. Hence somewhere in between the two edges the bending stress should be zero. The layer of zero stress due to bending is called **neutral layer** and the trace of neutral layer in the cross-section is called **neutral axis** [Refer Fig. 1].

## ASSUMPTIONS

Theory of simple bending is developed with the following assumptions which are reasonably acceptable:

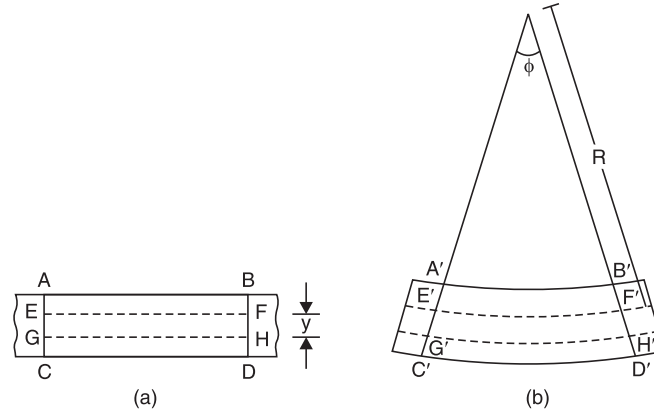
- (i) The material is homogeneous and isotropic.
- (ii) Modulus of elasticity is the same in tension and in compression.
- (iii) Stresses are within the elastic limit.
- (iv) Plane section remains plane even after deformations.
- (v) The beam is initially straight and every layer of it is free to expand or contract.
- (vi) The radius of curvature of bent beam is very large compared to depth of the beam.



## BENDING EQUATION

There exists a definite relationship among applied moment, bending stresses and bending deformation (radius of curvature). This relationship can be derived in two steps:

- (i) Relationship between bending stresses and radius of curvature.
  - (ii) Relationship between applied bending moment and radius of curvature.
- (i) *Relationship between bending stresses and radius of curvature:* Consider an elemental length  $AB$  of the beam as shown in Fig. 2(a). Let  $EF$  be the neutral layer and  $CD$  the bottom most layer. If  $GH$  is a layer at distance  $y$  from neutral layer  $EF$ , initially  $AB = EF = GH = CD$ .



**Fig. 2**

Let after bending  $A, B, C, D, E, F, G$  and  $H$  take positions  $A', B', C', D', E', F', G'$  and  $H'$  respectively as shown in Fig. 2(b). Let  $R$  be the radius of curvature and  $\phi$  be the angle subtended by  $C'A'$  and  $D'B'$  at centre of radius of curvature. Then,

$$\begin{aligned} EF &= E'F', \text{ since } EF \text{ is neutral axis} \\ &= R\phi \end{aligned} \quad \dots(i)$$

$$\text{Strain in } GH = \frac{\text{Final length} - \text{Initial length}}{\text{Initial length}}$$

$$= \frac{G'H' - GH}{GH}$$

But  $GH = EF$  (The initial length)

$$= R\phi$$

and  $G'H' = (R + y)\phi$

$$\begin{aligned} \therefore \text{Strain in layer } GH &= \frac{(R + y)\phi - R\phi}{R\phi} \\ &= \frac{y}{R} \end{aligned} \quad \dots(ii)$$

Since strain in  $GH$  is due to tensile forces, strain in  $GH = f/E$  ... (iii)

where  $f$  is tensile stress and  $E$  is modulus of elasticity.

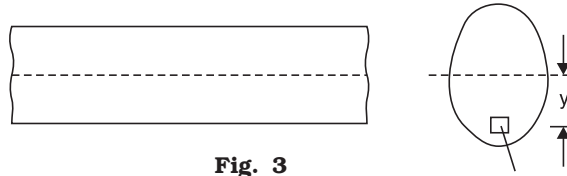
From eqns. (ii) and (iii), we get

$$\frac{f}{E} = \frac{y}{R}$$



or 
$$\frac{f}{y} = \frac{E}{R} \quad \dots(1)$$

(ii) *Relationship between bending moment and radius of curvature:* Consider an elemental area  $\delta a$  at distance  $y$  from neutral axis as shown in Fig. 3.



**Fig. 3**

From eqn. 1, stress on this element is

$$f = \frac{E}{R} y \quad \dots(i)$$

$\therefore$  Force on this element

$$= \frac{E}{R} y \delta a$$

Moment of resistance of this elemental force about neutral axis

$$\begin{aligned} &= \frac{E}{R} y \delta a y \\ &= \frac{E}{R} y^2 \delta a \end{aligned}$$

$\therefore$  Total moment resisted by the section  $M'$  is given by

$$\begin{aligned} M' &= \sum \frac{E}{R} y^2 \delta a \\ &= \frac{E}{R} \sum y^2 \delta a \end{aligned}$$

From the definition of moment of inertia (second moment of area) about centroidal axis, we know

$$I = \sum y^2 \delta a$$

$$\therefore M' = \frac{E}{R} I$$

From equilibrium condition,  $M = M'$  where  $M$  is applied moment.

$$\therefore M = \frac{E}{R} I$$

or 
$$\frac{M}{I} = \frac{E}{R} \quad \dots(2)$$

From eqns. (10.1) and (10.2), we get

$$\frac{M}{I} = \frac{f}{y} = \frac{E}{R} \quad \dots(3)$$





where  $M$  = bending moment at the section  
 $I$  = moment of inertia about centroid axis  
 $f$  = bending stress  
 $y$  = distance of the fibre from neutral axis  
 $E$  = modulus of elasticity and  
 $R$  = radius of curvature of bent section.  
Equation (3) is known as bending equation.

### LOCATING NEUTRAL AXIS

Consider an elemental area  $\delta a$  at a distance  $y$  from neutral axis [Ref. Fig. 3].

If ' $f$ ' is the stress on it, force on it =  $f \delta a$

But  $f = \frac{E}{R}y$ , from eqn. (1).

$\therefore$  Force on the element =  $\frac{E}{R} y \delta a$

Hence total horizontal force on the beam

$$= \sum \frac{E}{R} y \delta a$$

$$= \frac{E}{R} \sum y \delta a$$

Since there is no other horizontal force, equilibrium condition of horizontal forces gives

$$\frac{E}{R} \sum y \delta a = 0$$

As  $\frac{E}{R}$  is not zero,

$$\sum y \delta a = 0 \quad \dots(i)$$

If  $A$  is total area of cross-section, from eqn. (i), we get

$$\sum \frac{y \delta a}{A} = 0 \quad \dots(ii)$$

Noting that  $\sum y \delta a$  is the moment of area about neutral axis,  $\frac{\sum y \delta a}{A}$  should be the distance of

centroid of the area from the neutral axis. Hence  $\frac{\sum y \delta a}{A} = 0$  means the *neutral axis coincides with the centroid of the cross-section.*



## MOMENT CARRYING CAPACITY OF A SECTION From

bending equation, we have

$$\frac{M}{I} = \frac{f}{y}$$

i.e., 
$$f = \frac{M}{I} y \quad \dots(i)$$

Hence bending stress is maximum, when  $y$  is maximum. In other words, maximum stress occurs in the extreme fibres. Denoting extreme fibre distance from neutral fibre as  $y_{\max}$  equation (i) will be

$$f_{\max} = \frac{M}{I} y_{\max} \quad \dots(ii)$$

In a design  $f_{\max}$  is restricted to the permissible stress in the material. If  $f_{\text{per}}$  is the permissible stress, then from equation (ii),

$$f_{\text{per}} = \frac{M}{I} y_{\max}$$

$$\therefore M = \frac{I}{y_{\max}} f_{\text{per}}$$

The moment of inertia  $I$  and extreme fibre distance from neutral axis  $y_{\max}$  are the properties of section. Hence  $\frac{I}{y_{\max}}$  is the property of the section of the beam. This term is known as **modulus of section** and is denoted by  $Z$ . Thus

$$Z = \frac{I}{y_{\max}} \quad \dots(4)$$

and 
$$M = f_{\text{per}} Z \quad \dots(5)$$

**Note :** If moment of inertia has unit  $\text{mm}^4$  and  $y_{\max}$  has mm,  $Z$  has the unit  $\text{mm}^3$ .

The eqn. (5) gives permissible maximum moment on the section and is known as **moment carrying capacity of the section**. Since there is definite relation between bending moment and the loading given for a beam it is possible to find the load carrying capacity of the beam by equating maximum moment in the beam to moment carrying capacity of the section. Thus

$$M_{\max} = f_{\text{per}} Z \quad \dots(6)$$

If permissible stresses in tension and compressions are different for a material, moment carrying capacity in tension and compression should be found separately and equated to maximum values of moment creating tension and compression separately to find the load carrying capacity. The lower of the two values obtained should be reported as the load carrying capacity.

## SECTION MODULI OF STANDARD SECTIONS

Section modulus expressions for some of the standard sections are presented below:

(i) **Rectangular section:** Let width be ' $b$ ' and depth be ' $d$ ' as shown in Fig. 4.

Since  $N-A$  is in the mid depth

$$y_{\max} = d/2$$

$$I = \frac{1}{12} b d^3$$

$$\therefore Z = \frac{I}{y_{\max}} = \frac{1/12 b d^3}{d/2}$$

i.e., 
$$Z = 1/6 b d^2 \quad \dots(10.7)$$

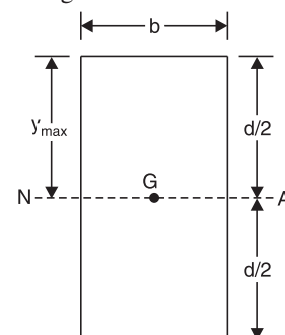


Fig. 4



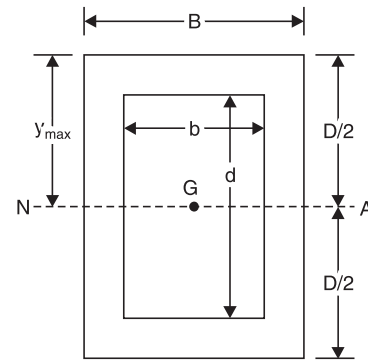
(ii) **Hollow rectangular section.** Figure 5 shows a typical hollow rectangular section with symmetric opening. For this,

$$I = \frac{BD^3}{12} - \frac{bd^3}{12} = \frac{1}{12} (BD^3 - bd^3)$$

$$y_{\max} = D/2$$

$$\therefore Z = \frac{I}{y_{\max}} = \frac{1}{12} \frac{(BD^3 - bd^3)}{D/2}$$

$$\text{i.e.} \quad Z = \frac{1}{6} \frac{BD^3 - bd^3}{D} \quad \dots(10.8)$$



**Fig. 5**

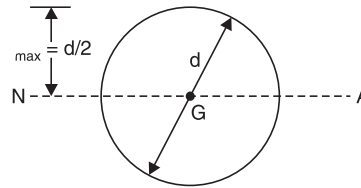
(iii) **Circular section of diameter 'd'.** Typical section is shown in Fig. 6. For this,

$$I = \frac{\pi}{64} d^4$$

$$y_{\max} = d/2$$

$$\therefore Z = \frac{I}{y_{\max}} = \frac{\pi/64 d^4}{d/2}$$

$$\text{i.e.,} \quad Z = \frac{\pi}{32} d^3$$



**Fig. 6**

(iv) **Hollow circular tube of uniform section.** Referring to Fig. 7,

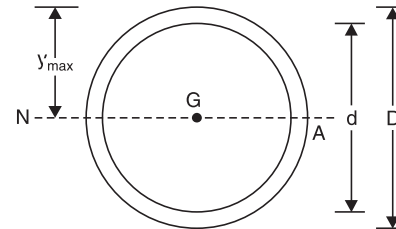
$$I = \frac{\pi}{64} D^4 - \frac{\pi}{64} d^4$$

$$= \frac{\pi}{64} (D^4 - d^4)$$

$$y_{\max} = D/2$$

$$\therefore Z = \frac{I}{y_{\max}} = \frac{\pi}{64} \frac{(D^4 - d^4)}{D/2}$$

$$\text{i.e.,} \quad Z = \frac{\pi}{32} \frac{D^4 - d^4}{D} \quad \dots(9)$$



**Fig. 7**

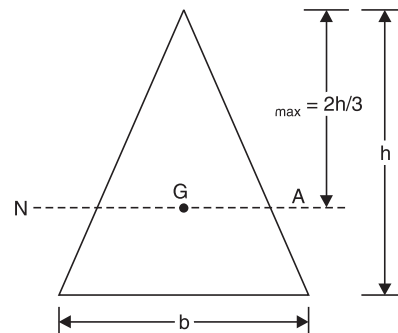
(v) **Triangular section of base width 'b' and height 'h'.** Referring to Fig. 8,

$$I = \frac{bh^3}{36}$$

$$y_{\max} = \frac{2}{3} h$$

$$\therefore Z = \frac{I}{y_{\max}} = \frac{bh^3/36}{2/3 h}$$

$$\text{i.e.,} \quad Z = \frac{bh^2}{24} \quad \dots(10)$$



**Fig. 8**

**Example 1.** A simply supported beam of span 3.0 m has a cross-section 120 mm × 180 mm. If the permissible stress in the material of the beam is 10 N/mm<sup>2</sup>, determine

(i) maximum udl it can carry

(ii) maximum concentrated load at a point 1 m from support it can carry.

Neglect moment due to self weight.



**Solution:**

Here  $b = 120 \text{ mm}$ ,  $d = 180 \text{ mm}$ ,  $I = \frac{1}{12} bd^3$ ,  $y_{\max} = \frac{d}{2}$

$$\begin{aligned} \therefore Z &= \frac{1}{6} bd^2 \\ &= \frac{1}{6} \times 120 \times 180^2 = 648000 \text{ mm}^3 \\ f_{\text{per}} &= 10 \text{ N/mm}^2 \end{aligned}$$

$$\begin{aligned} \therefore \text{Moment carrying capacity of the section} \\ &= f_{\text{per}} \times Z \end{aligned}$$

In this case, we know that maximum moment occurs at mid span and is equal to  $M_{\max} = \frac{wL^2}{8}$ .

Equating it to moment carrying capacity, we get,

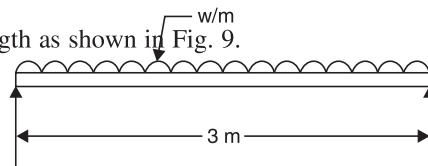
$$(i) \text{ Let maximum udl beam can carry be } w/\text{metre length as shown in Fig. 9.}$$

$$\frac{wL^2}{8} \times 10^6 = 10 \times 648000$$

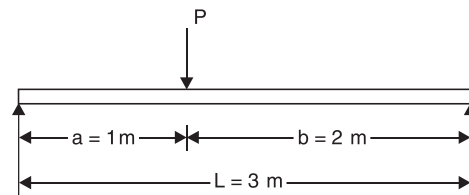
$$\therefore w = 5.76 \text{ kN/m.}$$

(ii) Concentrated load at distance 1 m from the support be  $P$  kN. Referring to Fig. 10.

$$\begin{aligned} M_{\max} &= \frac{P \times a \times b}{L} = \frac{P \times 1 \times 2}{3} \\ &= \frac{2P}{3} \text{ kN-m} \\ &= \frac{2P}{3} \times 10^6 \text{ N-mm} \end{aligned}$$



**Fig. 9**



**Fig. 10**

Equating it to moment carrying capacity, we get

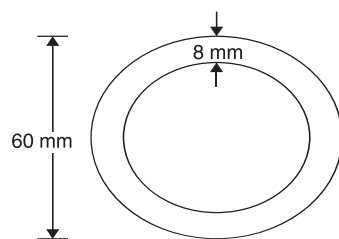
$$\frac{2P}{3} \times 10^6 = 10 \times 648000$$

$$\therefore P = 9.72 \text{ kN-m.}$$

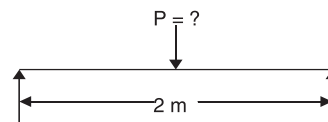
**Example 2.** A circular steel pipe of external diameter 60 mm and thickness 8 mm is used as a simply supported beam over an effective span of 2 m. If permissible stress in steel is  $150 \text{ N/mm}^2$ , determine the maximum concentrated load that can be carried by it at mid span.

**Solution:**

External diameter  $D = 60 \text{ mm}$   
Thickness  $= 8 \text{ mm}$



(a)



(b)

**Fig. 11**

$$\therefore \text{Internal diameter} = 60 - 2 \times 8 = 44 \text{ mm.}$$

$$I = \frac{\pi}{64} (60^4 - 44^4) = 452188 \text{ mm}^4$$



$$y_{\max} = 30 \text{ mm.}$$

$$\therefore Z = \frac{I}{y_{\max}} = \frac{452188}{30} = 15073 \text{ mm}^3.$$

Moment carrying capacity

$$M = f_{\text{per}} Z = 150 \times 15073 \text{ N-mm.}$$

Let maximum load it can carry be  $P$  kN.

$$\begin{aligned} \text{Then maximum moment} &= \frac{PL}{4} \\ &= \frac{P \times 2}{4} \text{ kN-m} \\ &= 0.5 P \times 10^6 \text{ N-mm.} \end{aligned}$$

Equating maximum bending moment to moment carrying capacity, we get

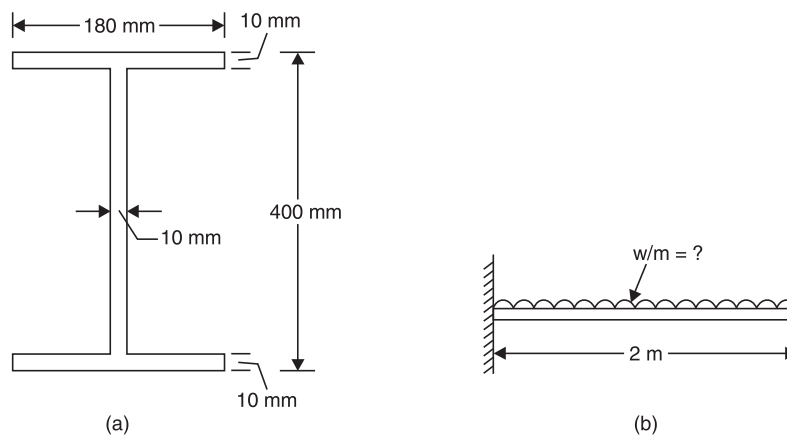
$$0.5P \times 10^6 = 150 \times 15073$$

$$\therefore P = 4.52 \text{ kN.}$$

**Example 3:** Figure 12 (a) shows the cross-section of a cantilever beam of 2.5 m span. Material used is steel for which maximum permissible stress is  $150 \text{ N/mm}^2$ . What is the maximum uniformly distributed load this beam can carry?

**Solution:** Since it is a symmetric section, centroid is at mid depth.

$I = MI$  of 3 rectangles about centroid



**Fig. 12**

$$\begin{aligned} &= \frac{1}{12} \times 180 \times 10^3 + 180 \times 10 (200 - 5)^2 \\ &\quad + \frac{1}{12} \times 10 \times (400 - 20)^3 + 10 \times (400 - 20) \times 0^2 \\ &\quad + \frac{1}{12} \times 180 \times 10^3 + 180 \times 10 (200 - 5)^2 \\ &= 182.6467 \times 10^6 \text{ mm}^4 \end{aligned}$$

[Note: Moment of above section may be calculated as difference between  $MI$  of rectangle of size  $180 \times 400$  and  $170 \times 380$ . i.e.,

$$\begin{aligned} I &= \frac{1}{12} \times 180 \times 400^3 - \frac{1}{12} \times 170 \times 380^3 \\ y_{\max} &= 200 \text{ mm.} \end{aligned}$$

$$Z = \frac{I}{y_{\max}} = \frac{182.6467 \times 10^6}{200} = 913233 \text{ mm}^3.$$



$$\begin{aligned}
\therefore \text{Moment carrying capacity} &= f_{\text{per}} \times Z \\
&= 180 \times 913233 \\
&= 136985000 \text{ N-mm.}
\end{aligned}$$

If  $udl$  is  $w$  kN/m, maximum moment in cantilever

$$\begin{aligned}
&= wL = 2w \text{ kN-mm} \\
&= 2w \times 10^6 \text{ N-mm}
\end{aligned}$$

Equating maximum moment to moment carrying capacity of the section, we get

$$2w \times 10^6 = 136985000$$

$$\therefore w = \mathbf{68.49 \text{ kN/m}}$$

**Example 4.** Compare the moment carrying capacity of the section given in example 10.3 with equivalent section of the same area but

- (i) square section
- (ii) rectangular section with depth twice the width and
- (iii) a circular section.

**Solution:**

$$\begin{aligned}
\text{Area of the section} &= 180 \times 10 + 380 \times 10 + 180 \times 10 \\
&= 7400 \text{ mm}^2
\end{aligned}$$

(i) Square section

If 'a' is the size of the equivalent square section,

$$a^2 = 7400 \quad \therefore a = 86.023 \text{ mm.}$$

Moment of inertia of this section

$$\begin{aligned}
&= \frac{1}{12} \times 86.023 \times 86.023^3 \\
&= 4563333 \text{ mm}^4
\end{aligned}$$

$$Z = \frac{I}{y_{\text{max}}} = \frac{4563333}{86.023/2} = 106095.6 \text{ mm}^3$$

$$\begin{aligned}
\text{Moment carrying capacity} &= fZ = 150 \times 106095.6 \\
&= 15.914 \times 10^6 \text{ N-mm}
\end{aligned}$$

$$\therefore \frac{\text{Moment carrying capacity of I section}}{\text{Moment carrying capacity of equivalent square section}} = \frac{136985000}{15.914 \times 10^6} = \mathbf{8.607.}$$

(ii) Equivalent rectangular section of depth twice the width.

Let  $b$  be the width

$\therefore$  Depth  $d = 2b$ .

Equating its area to area of I-section, we get

$$b \times 2b = 7400$$

$$b = 60.8276 \text{ mm}$$

$$y_{\text{max}} = d/2 = b = 60.8276$$

$$\begin{aligned}
M &= f \frac{I}{y_{\text{max}}} = 150 \times \frac{1}{12} \times \frac{b \times (2b)^3}{b} \\
&= 150 \times \frac{8}{12} b^3 = 150 \times \frac{8}{12} \times 60.8276^3 \\
&= 22506193 \text{ N-mm.}
\end{aligned}$$

$$\therefore \frac{\text{Moment carrying capacity of I section}}{\text{Moment carrying capacity of this section}} = \frac{136985000}{22506193} = \mathbf{6.086.}$$



(iii) Equivalent circular section.

Let diameter be  $d$ .

Then, 
$$\frac{\pi d^2}{4} = 7400$$

$$d = 97.067$$

$$I = \frac{\pi}{64} d^4$$

$$y_{\max} = d/2$$

$$\therefore Z = \frac{I}{y_{\max}} = \frac{\pi}{32} d^3.$$

$$M = f_{\text{per}} Z = 150 \times \frac{\pi}{32} \times 97.067^3 = 13468024$$

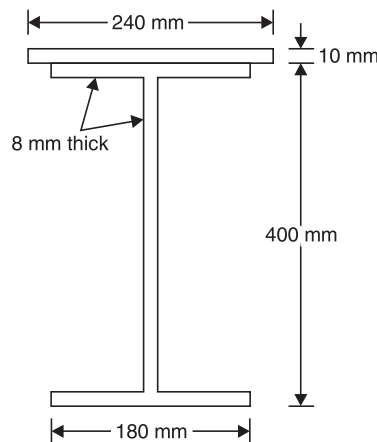
$$\therefore \frac{\text{Moment carrying capacity of I section}}{\text{Moment carrying capacity of circular section}} = \frac{136985000}{13468024} = 10.17.$$

[Note. I section of same area resists more bending moment compared to an equivalent square, rectangular or circular section. Reason is obvious because in I-section most of the area of material is in heavily stressed zone.]

**Example 15.** A symmetric I-section of size 180 mm × 40 mm, 8 mm thick is strengthened with 240 mm × 10 mm rectangular plate on top flange as shown in Fig. 13. If permissible stress in the material is 150 N/mm<sup>2</sup>, determine how much concentrated load the beam of this section can carry at centre of 4 m span. Given ends of beam are simply supported.

**Solution:** Area of section A

$$= 240 \times 10 + 180 \times 8 + 384 \times 8 + 180 \times 8 = 8352 \text{ mm}^2$$



**Fig. 13**

Let centroid of the section be at a distance  $\bar{y}$  from the bottom most fibre. Then

$$A \bar{y} = 240 \times 10 \times 405 + 180 \times 8 \times (400 - 4) + 384 \times 8 \times 200 + 180 \times 8 \times 4$$

i.e.,  $8352 \bar{y} = 2162400$

$\therefore \bar{y} = 258.9 \text{ mm}$

$$I = \frac{1}{12} \times 240 \times 10^3 + 240 \times 10 (405 - 258.9)^2$$

$$+ \frac{1}{12} \times 180 \times 8^3 + 180 \times 8 (396 - 258.9)^2$$

$$+ \frac{1}{12} \times 8 \times 384^3 + 8 \times 384 (200 - 258.9)^2$$

$$+ \frac{1}{12} \times 180 \times 8^3 + 180 \times 8 (4 - 258.9)^2$$



$$= 220.994 \times 10^6 \text{ mm}^4$$

$$\therefore y_{\text{top}} = 405 - 258.9 = 146.1 \text{ mm}$$

$$y_{\text{bottom}} = 258.9 \text{ mm.}$$

$$\therefore y_{\text{max}} = 258.9 \text{ mm}$$

$$\therefore Z = \frac{I}{y_{\text{max}}} = \frac{220.994 \times 10^6}{258.9} = 853588.3$$

$$\therefore \text{Moment carrying capacity of the section}$$

$$= f_{\text{per}} Z = 150 \times 853588.3$$

$$= 128038238.7 \text{ N-mm}$$

$$= 128.038 \text{ kN-m.}$$

Let  $P$  kN be the central concentrated load the simply supported beam can carry. Then max bending movement in the beam

$$= \frac{P \times 4}{4} = P \text{ kN-m}$$

Equating maximum moment to moment carrying capacity, we get

$$P = 128.038 \text{ kN.}$$

**Example 6.** The cross-section of a cast iron beam is as shown in Fig. 14(a). The top flange is in compression and bottom flange is in tension. Permissible stress in tension is  $30 \text{ N/mm}^2$  and its value in compression is  $90 \text{ N/mm}^2$ . What is the maximum uniformly distributed load the beam can carry over a simply supported span of 5 m?

**Solution:**

$$\text{Cross-section area } A = 75 \times 50 + 25 \times 100 + 150 \times 50$$

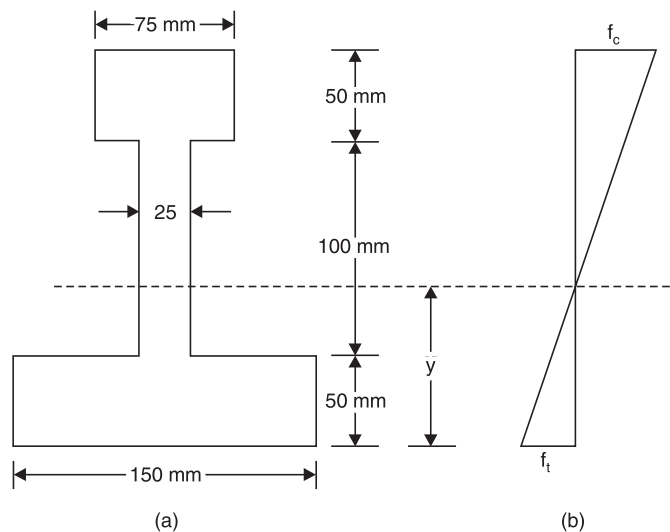
$$= 13750 \text{ mm}^2$$

Let neutral axis lie at a distance  $\bar{y}$  from bottom most fibre. Then

$$A\bar{y} = 75 \times 50 \times 175 + 25 \times 100 \times 100 + 150 \times 50 \times 25$$

$$13750 \times \bar{y} = 1093750$$

$$\therefore \bar{y} = 79.54 \text{ mm}$$



**Fig. 14**





$$\begin{aligned}
 \therefore I &= \frac{1}{12} \times 75 \times 50^3 + 75 \times 50 (175 - 79.54)^2 \\
 &+ \frac{1}{12} \times 25 \times 100^3 + 25 \times 100 (100 - 79.54)^2 \\
 &+ \frac{1}{12} \times 150 \times 50^3 + 150 \times 50 (25 - 79.54)^2 \\
 &= 61.955493 \times 10^6 \text{ mm}^4.
 \end{aligned}$$

Extreme fibre distances are

$$y_{\text{bottom}} = \bar{y} = 79.54 \text{ mm.}$$

$$y_{\text{top}} = 200 - \bar{y} = 200 - 79.54 = 120.46 \text{ mm.}$$

Top fibres are in compression. Hence from consideration of compression strength, moment carrying capacity of the beam is given by

$$\begin{aligned}
 M_1 &= f_{\text{per}} \text{ in compression} \times \frac{I}{y_{\text{top}}} \\
 &= 90 \times \frac{61.955493 \times 10^6}{120.46} \\
 &= 46.289178 \times 10^6 \text{ N-mm} \\
 &= 46.289178 \text{ kN-m.}
 \end{aligned}$$

Bottom fibres are in tension. Hence from consideration of tension, moment carrying capacity of the section is given by

$$\begin{aligned}
 M_2 &= f_{\text{per}} \text{ in tension} \times \frac{I}{y_{\text{bottom}}} \\
 &= \frac{30 \times 61.955493 \times 10^6}{79.54} \\
 &= 21.367674 \times 10^6 \text{ N-mm} \\
 &= 21.367674 \text{ kN-m.}
 \end{aligned}$$

Actual moment carrying capacity is the lower value of the above two values. Hence moment carrying capacity of the section is

$$= 21.367674 \text{ kN-m.}$$

Maximum moment in a simply supported beam subjected to *udl* of *w*/unit length and span *L* is

$$= \frac{wL^2}{8}$$

Equating maximum moment to moment carrying capacity of the section, we get maximum load carrying capacity of the beam as

$$w \times \frac{5^2}{8} = 21.367674$$

$$\therefore w = 6.838 \text{ kN/m.}$$



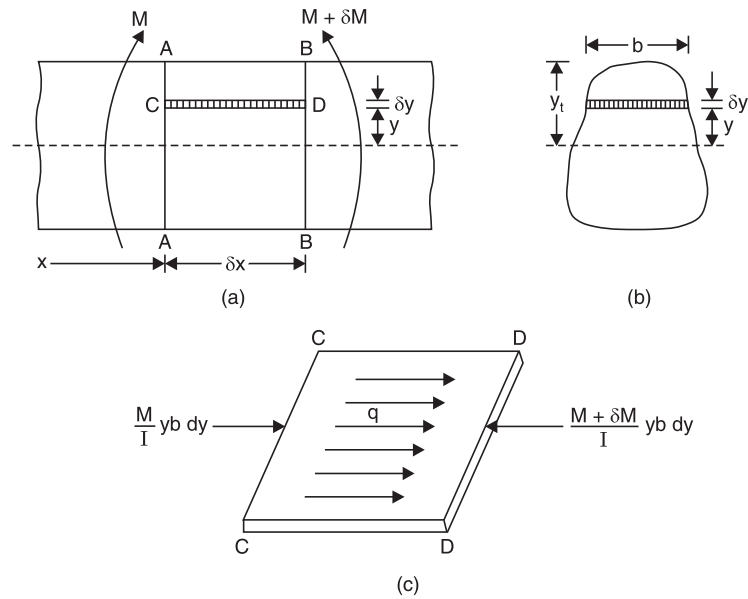
# SHEAR STRESS DISTRIBUTION

## Expression for Shear Stress

Consider an elemental length ' $\delta x$ ' of beam shown in Fig. 15 (a). Let bending moment at section A-A be  $M$  and that at section B-B be  $M + \delta M$ . Let  $CD$  be an elemental fibre at distance  $y$  from neutral axis and its thickness be  $\delta y$ . Then,

Bending stress on left side of elemental fibre

$$= \frac{M}{I} y$$



**Fig. 15**

$\therefore$  The force on left side of element

$$= \frac{M}{I} y b \delta y$$

Similarly, force on right side on elemental fibre

$$= \frac{M + \delta M}{I} y b \delta y$$

$\therefore$  Unbalanced horizontal force on right side of elemental fibre

$$\begin{aligned} &= \frac{M + \delta M}{I} y b \delta y - \frac{M}{I} y b \delta y \\ &= \frac{\delta M}{I} y b \delta y \end{aligned}$$

There are a number of such elemental fibres above  $CD$ . Hence unbalanced horizontal force on section  $CD$



$$\begin{aligned}
 &= \int_y^{y'} \frac{dM}{I} y b \delta y \\
 &= \int_y^{y'} \frac{dM}{I} y b dy = \frac{\delta M}{I} \int_y^{y'} yb dy
 \end{aligned}$$

Let intensity of shearing stress on element  $CD$  be  $q$ . [Refer Fig. 15 (c)]. Then equating resisting shearing force to unbalanced horizontal force, we get

$$q b \delta x = \frac{\delta M}{I} \int_y^{y'} yb dy$$

$$\therefore q = \frac{\delta M}{\delta x} \frac{1}{bI} \int_y^{y'} yb dy$$

$$\text{As } \delta x \rightarrow 0, \quad q = \frac{dM}{dx} \frac{1}{bI} (a\bar{y})$$

where  $a\bar{y}$  = Moment of area above the section under consideration about neutral axis.

$$\text{But we know } \frac{dM}{dx} = F$$

$$\therefore q = \frac{F}{bI} (a\bar{y}) \quad \dots(11)$$

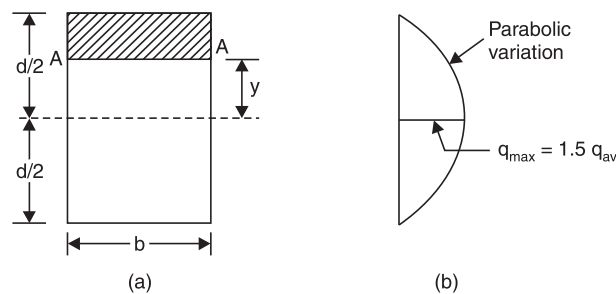
The above expression gives shear stress at any fibre  $y$  distance above neutral axis.

### Variation of Shear Stresses Across Standard Sections

Variation of shear stresses across the following three cases are discussed below:

- (i) Rectangular
- (ii) Circular and
- (iii) Isosceles triangle.

- (i) **Rectangular section.** Consider the rectangular section of width ' $b$ ' and depth shown in Fig. 10.18(a). Let  $A-A$  be the fibre at a distance  $y$  from neutral axis. Let the shear force on the section be  $F$ .



**Fig. 16**

From equation (11), shear stress at this section is

$$q = \frac{F}{bI} (a\bar{y})$$

where  $(a\bar{y})$  is the moment of area above the section about the neutral axis. Now,

$$a = b(d/2 - y)$$



$$\bar{y} = y + \frac{1}{2} (d/2 - y) = \frac{1}{2} (d/2 + y)$$

$$\begin{aligned} \therefore a\bar{y} &= \frac{b}{2} (d/2 - y) \times \frac{1}{2} (d/2 + y) \\ &= \frac{b}{2} (d^2/4 - y^2) \end{aligned}$$

$$I = \frac{1}{12} bd^3$$

$$\begin{aligned} \therefore q &= \frac{F}{b \frac{1}{12} bd^3} \frac{b}{2} (d^2/4 - y^2) \\ &= \frac{6F}{bd^3} (d^2/4 - y^2) \end{aligned}$$

This shows shear stress varies parabolically.

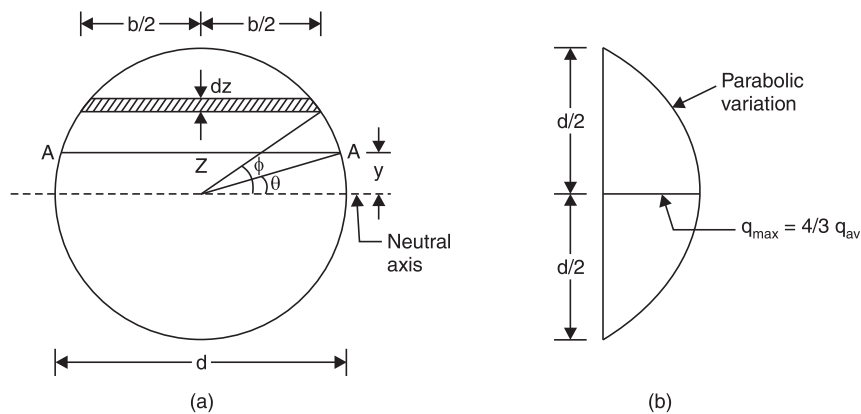
When  $y = \pm d/2$ ,  $q = 0$

$$\begin{aligned} \text{At } y = 0, \quad q_{\max} &= \frac{6F}{bd^3} \frac{d^2}{4} = 1.5 \frac{F}{bd} \\ &= 1.5 q_{av} \end{aligned}$$

where  $q_{av} = \frac{F}{bd}$  is average shear stress.

Thus in rectangular section maximum shear stress is at neutral axis and it is 1.5 times average shear stress. It varies parabolically from zero at extreme fibres to  $1.5 q_{av}$  at mid depth as shown in Fig. 16(b).

(ii) **Circular section.** Consider a circular section of diameter 'd' as shown in Fig. 17(a) on which a shear force  $F$  is acting. Let A-A be the section at distance 'y' from neutral axis at which shear stress is to be found. To find moment of area of the portion above A-A about neutral axis, let us consider an element at distance 'z' from neutral axis. Let its thickness be  $dz$ . Let it be at an angular distance  $\phi$  and A-A be at angular distance  $\theta$  as shown in figure.



**Fig. 17**



Width of element  $b = 2 \cdot \frac{d}{2} \cos \phi$

$$= d \cos \phi$$

$$z = \frac{d}{2} \sin \phi$$

$$\therefore dz = \frac{d}{2} \cos \phi d\phi$$

$\therefore$  Area of the element

$$\begin{aligned} a &= bdz = d \cos \phi \cdot \frac{d}{2} \cos \phi d\phi \\ &= \frac{d^2}{2} \cos^2 \phi d\phi \end{aligned}$$

Moment of this area about neutral axis

$$= \text{area} \times z$$

$$= \frac{d^2}{2} \cos^2 \phi d\phi \cdot \frac{d}{2} \sin \phi$$

$$= \frac{d^3}{4} \cos^2 \phi \sin \phi d\phi$$

$\therefore$  Moment of area about section A-A about neutral axis

$$\begin{aligned} (a\bar{y}) &= \int_0^{\pi/2} \frac{d^2}{4} \cos^2 \phi \sin \phi d\phi \\ &= \frac{d^3}{4} \left[ \frac{-\cos^3 \phi}{3} \right]_0^{\pi/2} \end{aligned}$$

[Since if  $\cos \phi = t$ ,  $dt = -\sin \phi d\phi$  and  $-t^3/3$  is integration]

$$\begin{aligned} \therefore (a\bar{y}) &= \frac{d^3}{4 \times 3} \left[ -\cos^2 \frac{\pi}{2} + \cos^3 \theta \right] \\ &= \frac{d}{12} \cos^3 \theta \end{aligned}$$

Now  $I = \frac{\pi d^4}{64}$

$$\therefore q = \frac{F}{bI} (a\bar{y})$$

$$= \frac{F}{d \cos \theta \frac{\pi}{64} d^4} \times \frac{d^3}{12} \cos^3 \theta$$

$$= \frac{64}{12} \frac{F}{\pi d^2} \cos^2 \theta$$

$$= \frac{16}{3} \frac{F}{\pi d^2} [1 - \sin^2 \theta]$$

$$= \frac{16}{3} \frac{F}{\pi d^2} \left[ 1 - \left( \frac{y}{d/2} \right)^2 \right]$$

$$= \frac{16}{3} \frac{F}{\pi d^2} \left[ 1 - \frac{4y^2}{d^2} \right]$$



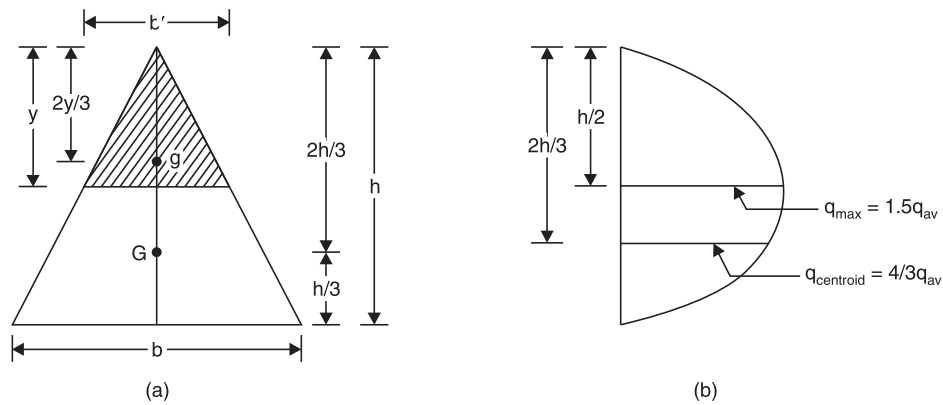
Hence shear stress varies parabolically.

$$\begin{aligned} \text{At } y = \pm d/2, \quad q &= 0 \\ y = 0, \quad q &= q_{\max} = \frac{16}{3} \frac{F}{\pi d^2} \\ &= \frac{4}{3} \frac{F}{\pi/4 d^2} \\ &= \frac{4}{3} \frac{F}{\text{Area}} \\ &= \frac{4}{3} q_{\text{av}} \end{aligned}$$

where  $q_{\text{av}}$  = average shear stress.

Thus in circular sections also shear stress varies parabolically from zero at extreme edges to the maximum value of  $\frac{4}{3} q_{\text{av}}$  at mid depth as shown in Fig. 17(b).

(iii) **Isosceles triangular section.** Consider the isosceles triangular section of width 'b' and height 'h' as shown in Fig. 18(a). Its centroid and hence neutral axis is at  $\frac{2h}{3}$  from top fibre. Now shear stress is to be found at section A-A which is at a depth 'y' from top fibre.



**Fig. 18**

At A-A width  $b' = \frac{y}{h} b$

$$\begin{aligned} \text{Area above A-A} \quad a &= \frac{1}{2} b' y \\ &= \frac{1}{2} \frac{b}{h} y^2 \end{aligned}$$

Its centroid from top fibre is at  $\frac{2y}{3}$ .

$$\therefore \text{Distance of shaded area above the section A-A from neutral axis } \bar{y} = \frac{2h}{3} - \frac{2y}{3}$$

$$\begin{aligned} \therefore a \bar{y} &= \frac{1}{2} \frac{b}{h} y^2 \left( \frac{2h}{3} - \frac{2y}{3} \right) \\ &= \frac{1}{3} \frac{b}{h} y^2 (h - y) \end{aligned}$$

Moment of inertia of the section

$$I = \frac{bh^3}{36}$$



∴ Shear stress at A-A

$$\begin{aligned}
 q &= \frac{F}{bl} a\bar{y} \\
 &= \frac{F}{\frac{y}{h} b \times \frac{bh^3}{36}} \times \frac{1}{3} \frac{b}{h} y^2 (h - y) \\
 &= \frac{12 F}{bh^3} y(h - y)
 \end{aligned}$$

Hence at  $y = 0$ ,  $q = 0$

At  $y = h$ ,  $q = 0$

At centroid,  $y = \frac{2h}{3}$

$$\begin{aligned}
 q &= \frac{12 F}{bh^3} \frac{2h}{3} (h - 2h/3) \\
 &= \frac{8 F}{3 bh} = \frac{4}{3} \frac{F}{1/2 bh} \\
 &= \frac{4}{3} q_{av}
 \end{aligned}$$

where  $q_{av}$  is average shear stress.

For  $q_{max}$ ,  $\frac{dq}{dy} = 0$

i.e.,  $\frac{12 F}{bh^3} (h - 2y) = 0$

i.e., at  $y = h/2$

and hence

$$\begin{aligned}
 q_{max} &= \frac{12 F}{bh^3} \cdot \frac{h}{2} (h - h/2) \\
 &= \frac{12 F}{4 bh} = \frac{3F}{bh} \\
 &= \frac{1.5 F}{1/2 bh} \\
 &= 1.5 q_{av}.
 \end{aligned}$$

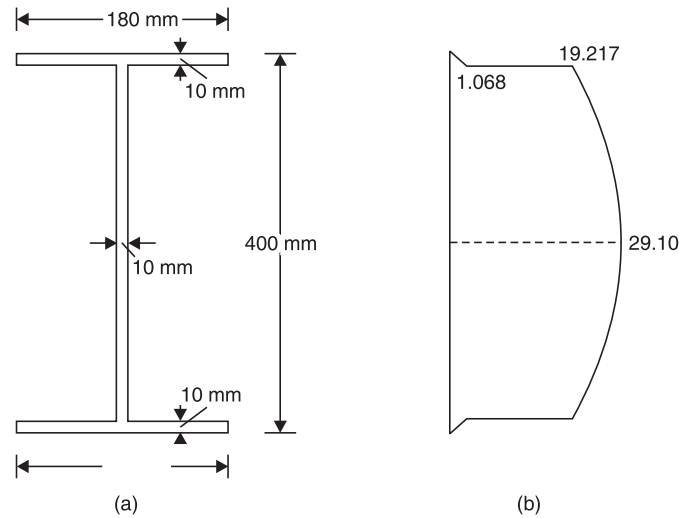
Thus in isosceles triangular section shear stress is zero at extreme fibres, it is maximum of  $1.5 q_{av}$  at mid depth and has a value  $\frac{4}{3} q_{av}$  at neutral axis. The variation of shear stress is as shown in Fig. 18(b).



## SHEAR STRESSES IN BUILT-UP SECTIONS

In sections like *I*, *T* and channel, shear stresses at various salient points are calculated and the shear stress variation diagram across depth is plotted. It may be noted that at extreme fibres shear stress is zero since ( $ay$ ) term works out to be zero. However it may be noted that the procedure explained below is for built up section with at least one symmetric axis. If there is no symmetric axis along the depth analysis for shear stress is complex, and that is treated beyond the scope to this book.

**Example 7.** Draw the shear stress variation diagram for the *I*-section shown in Fig. 10.21(a) if it is subjected to a shear force of 100 kN.



**Fig. 19**

**Solution:** Due to symmetry neutral axis is at mid depth.

$$\begin{aligned}
 I &= \frac{1}{12} \times 180 \times 10^3 + 180 \times 10 \times (200 - 5)^2 \\
 &\quad + \frac{1}{12} \times 10 \times 380^2 + 10 \times 380 \times (200 - 200)^2 \\
 &\quad + \frac{1}{12} \times 180 \times 10^3 + 180 \times 10 \times (200 - 5)^2 \\
 &= 182.646666 \times 10^6 \text{ mm}^4
 \end{aligned}$$

Shear stress at  $y = 200$  mm is zero since  $ay = 0$ .

Shear stress at bottom of top flange

$$\begin{aligned}
 &= \frac{F}{bl} (a\bar{y}) \\
 &= \frac{100 \times 1000}{180 \times 182.646666 \times 10^6} \times (180 \times 10 \times 195) \\
 &= 1.068 \text{ N/mm}^2
 \end{aligned}$$

Shear stress in the web at the junction with flange

$$\begin{aligned}
 &= \frac{100 \times 1000}{10 \times 182.646666 \times 10^6} (180 \times 10 \times 195) \\
 &= 19.217 \text{ N/mm}^2
 \end{aligned}$$





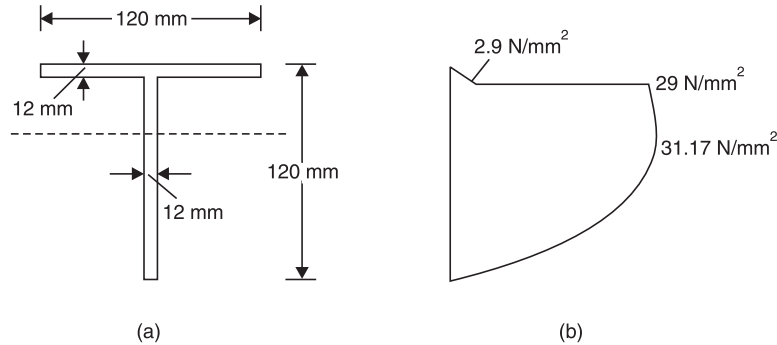
Shear stress at  $N-A$

$$= \frac{100 \times 1000}{10 \times 182.646666} \times \left[ 180 \times 10 \times 195 + 10 \times (200 - 10) \times \frac{190}{2} \right]$$

$$= 29.10 \text{ N/mm}^2.$$

Symmetric values will be there on lower side. Hence shear stress variation is as shown in Fig. 19(b).

**Example 8.** A beam has cross-section as shown in Fig. 20(a). If the shear force acting on this is 25 kN, draw the shear stress distribution diagram across the depth.



**Fig. 20**

**Solution:** Let  $\bar{y}$  be the distance of centroid of the section from its top fibre. Then

$$y' = \frac{\text{Moment of area about top fibre}}{\text{Total area}}$$

$$= \frac{120 \times 12 \times 6 + (120 - 12) \times 12 \times \left( 12 + \frac{120 - 12}{2} \right)}{120 \times 12 + (120 - 12) \times 12}$$

$$= 34.42 \text{ mm}$$

$\therefore$  Moment of inertia about centroid

$$I = \frac{1}{12} \times 120 \times 12^3 + 120 \times 12 (34.42 - 6)^2$$

$$+ \frac{1}{12} \times 12 \times 108^3 + 12 \times 108 \left( 34.42 - \frac{108}{2} \right)^2$$

$$= 2936930 \text{ mm}^4$$

Shear stresses are zero at extreme fibres.

Shear stress at bottom of flange:

$$\text{Area above this level, } a = 120 \times 12 = 1440 \text{ mm}^2$$

Centroid of this area above  $N-A$

$$\bar{y} = 34.42 - 6 = 28.42 \text{ mm}$$

Width at this level  $b = 120 \text{ mm}$ .

$$\therefore q_{\text{bottom of flange}} = \frac{25 \times 1000}{120 \times 2936930} \times 1440 \times 28.42$$

$$= 2.90 \text{ N/mm}^2$$

Shear stress at the same level but in web, where width  $b = 12 \text{ mm}$



$$= \frac{25 \times 1000}{12 \times 2936930} \times 1440 \times 28.42$$

$$= 29.0 \text{ N/mm}^2$$

Shear stress at neutral axis:

For this we can consider  $a\bar{y}$  term above this section or below this section. It is convenient to consider the term below this level.

$$a = 12 \times (120 - 34.42) = 1026.96 \text{ mm}^2$$

The distance of its centroid from N-A

$$= \frac{120 - 34.42}{2} = 42.79 \text{ mm.}$$

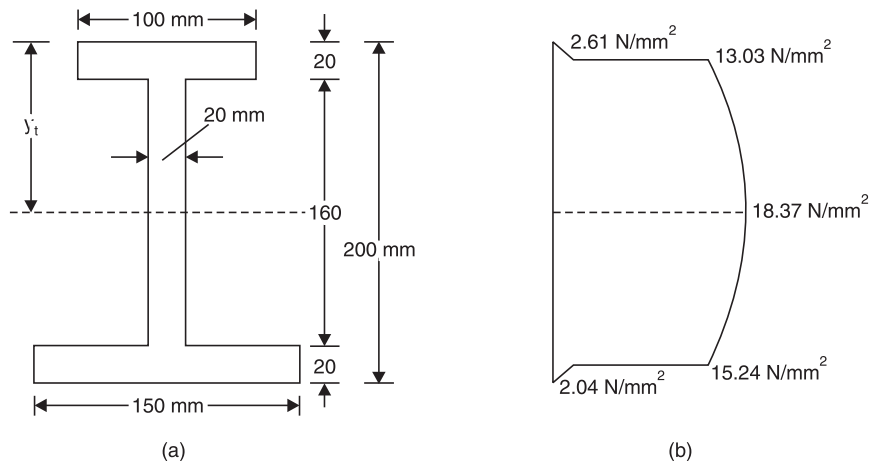
Width at this section  $b = 12 \text{ mm.}$

$$\therefore q = \frac{25 \times 1000}{12 \times 2936930} \times 1026.96 \times 42.79$$

$$= 31.17 \text{ N/mm}^2$$

Hence variation of shear stress across the depth is as shown in Fig. 10.22(b).

**Example 9.** The unsymmetric I-section shown in Fig. 21(a) is the cross-section of a beam, which is subjected to a shear force of 60 kN. Draw the shear stress variation diagram across the depth.



**Fig. 21**

**Solution:** Distance of neutral axis (centroid) of the section from top fibre be  $y_r$ . Then

$$y_r = \frac{100 \times 20 \times 10 + (200 - 20 - 20) \times 20 \times \left(20 + \frac{160}{2}\right) + 150 \times 20 \times (200 - 10)}{100 \times 20 + 160 \times 20 + 150 \times 20}$$

$$= 111 \text{ mm}$$

$$I = \frac{1}{12} \times 100 \times 20^3 + 100 \times 20 (111 - 10)^2$$

$$+ \frac{1}{12} \times 20 \times 160^3 + 160 \times 20 (111 - 100)^2$$

$$+ \frac{1}{12} \times 150 \times 20^3 + 150 \times 20 (111 - 190)^2$$



$$= 46505533 \text{ mm}^4$$

Shear stress at bottom of top flange

$$\begin{aligned} &= \frac{F}{bI} a\bar{y} \\ &= \frac{60 \times 1000}{100 \times 46505533} \times 100 \times 20 \times (111 - 10) \\ &= 2.61 \text{ N/mm}^2 \end{aligned}$$

∴ Shear stress at the same level, but in web

$$\begin{aligned} &= \frac{60 \times 1000}{20 \times 46505533} \times 100 \times 20 (111 - 10) \\ &= 13.03 \text{ N/mm}^2 \end{aligned}$$

Shear stress at neutral axis:

$$\begin{aligned} a\bar{y} &= a\bar{y} \text{ of top flange} + a\bar{y} \text{ of web above } N-A \\ &= 100 \times 20 \times (111 - 10) + 20 \times (111 - 20) \times \frac{111 - 20}{2} \\ &= 284810 \text{ mm}^3. \end{aligned}$$

∴ Shear stress at neutral axis

$$\begin{aligned} &= \frac{F}{bI} (a\bar{y}) \\ &= \frac{60 \times 1000}{20 \times 46505533} \times 284810 \\ &= 18.37 \text{ N/mm}^2. \end{aligned}$$

Shear stress at junction of web and lower flange:

Considering the lower side of the section for finding  $a\bar{y}$ , we get

$$a\bar{y} = 150 \times 20 \times (190 - 111) = 237000 \text{ mm}^3$$

∴

$$\begin{aligned} q &= \frac{60 \times 1000}{20 \times 46505533} \times 237000 \\ &= 15.28 \text{ N/mm}^2 \end{aligned}$$

At the above level but in web, shear stress

$$\begin{aligned} &= \frac{60 \times 1000}{150 \times 46505533} \times 237000 \\ &= 2.04 \text{ N/mm}^2 \end{aligned}$$

At extreme fibres shear stress is zero. Hence variation of shear across the depth of the section is as shown in Fig. 21.



## IMPORTANT FORMULAE

1. Bending equation:  $\frac{M}{I} = \frac{f}{y} = \frac{E}{R}$ .

2. Modulus of section  $Z = \frac{I}{y_{\max}}$ .

3. Moment carrying capacity of section =  $f_{\text{per}} Z$ .

4. Section modulus of various sections:

(i) Rectangular:  $\frac{1}{6} bd^2$       (ii) Hollow rectangular:  $\frac{1}{6} \frac{BD^3 - bd^3}{D}$

(iii) Solid circular section:  $\frac{\pi}{32} d^3$       (iv) Hollow circular section:  $\frac{\pi}{32} \frac{D^4 - d^4}{D}$

(v) Solid triangular section:  $\frac{bh^2}{24}$

5. Shear stress in a beam  $q = \frac{F}{bI} (a\bar{y})$

6. In rectangular sections,

$$q_{\max} = 1.5 q_{\text{av}}, \text{ at } y = d/2$$

In circular sections  $q_{\max} = \frac{4}{3} q_{\text{av}}$ , at centre

In triangular section,  $q_{\max} = 1.5 q_{\text{av}}$ , at  $y = \frac{h}{2}$ .



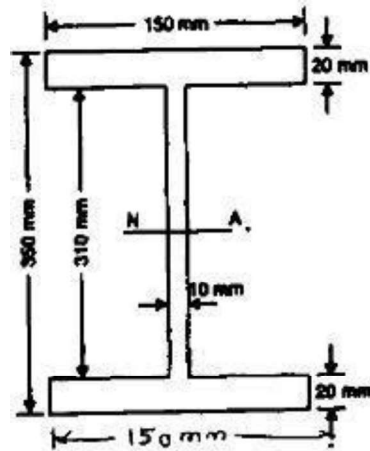
### Tutorial Question

1. Derive the equation of bending moment and write down the assumptions for theory of simple bending.
2. A simply supported beam carries a U.D.L. of intensity 2.5 kN/metre over entire span of 5 meters. The cross-section of the beam is a T-section having the dimensions  
Top flange: 125 mm cm X 25 mm  
Web: 175 mm cm X 25 mm  
Calculate the maximum shear stress for the section of the beam.
3. A cantilever beam of length 10 m has a cross section of 100 mm X 130 mm has a UDL of 10 KN/m over a length of 8 m from the left support and a concentrated load of 10 KN at the right end. Find the bending stress in the beam
4. A beam of T - section is having flange 120mm × 15mm and web 100mm × 15mm. It is subjected to a shear force of 24kN. Draw shear stress distribution across the depth marking values at salient points.
5. An I section is having overall depth as 550mm and overall width as 200mm. The thickness of the flanges is 25mm where as the thickness of the web is 20mm. If the section carries a shear force of 45kN, calculate the shear stress values at salient points and draw the sketch showing variation of shear stress.



### Assignment Questions

1. An I section beam 350 x 150 mm as shown in Fig. has a web thickness of 10 mm and a flange thickness of 20 mm. If the shear force acting on the section is 40kN, find the maximum shear stress developed in the I section
2. A rectangular beam 300 mm deep is simply supported over a span of 4m. Determine the



uniformly distributed load per meter which the beam may carry, if the bending stress should not exceed  $120 \text{ N/mm}^2$ . Take  $I = 8 \times 10^6 \text{ mm}^4$ .

3. An I-section beam 350mmX200mm has a web thickness of 12.5mm and a flange thickness of 25mm. It carries a shearing force of 200kN at a section. Sketch the shear stress distribution across the section.
4. A rolled steel joist 200mmx160mm wide has flange 22mm thick and web 12mm thick. Find the proportion, in which the flanges and web resist shear force.
5. A simply supported beam of 2m span carries a U.D.L. of 140 kN/m over the whole span. The cross section of the beam is T-section with a flange width of 120mm, web and flange thickness of 20mm and overall depth of 160mm. Determine the maximum shear stress in the beam and draw the shear stress distribution for the section.
6. A simply supported symmetric I-section has flanges of size 200 mmX 15 mm and its overall depth is 520 mm. Thickness of web is 10mm. It is strengthened with a plate of size 250 mm X 12mm on compression side. Find the moment of resistance of the section if permissible stress is 160 M Pa. How much uniformly distributed load it can carry if it is used as a cantilever of span 3.6m.



---

**UNIT 4**

**DEFLECTION OF BEAMS**

---

**Course Objectives:**

- To understand the behavior of beams under complex loading.

**Course Outcomes:**

- Evaluate the deflections in beams subjected to different loading conditions.



## Deflection of Beam

### Methods to compute deflections in beam

- Double integration method (*without* the use of singularity functions)
- Macaulay's Method (*with* the use of singularity functions)
- Moment area method

### Assumptions in Simple Bending Theory

- Beams are initially straight
- The material is homogenous and isotropic i.e. it has a uniform composition and its mechanical properties are the same in all directions
- The stress-strain relationship is linear and elastic
- Young's Modulus is the same in tension as in compression
- Sections are symmetrical about the plane of bending
- Sections which are plane before bending remain plane after bending

### Non-Uniform Bending

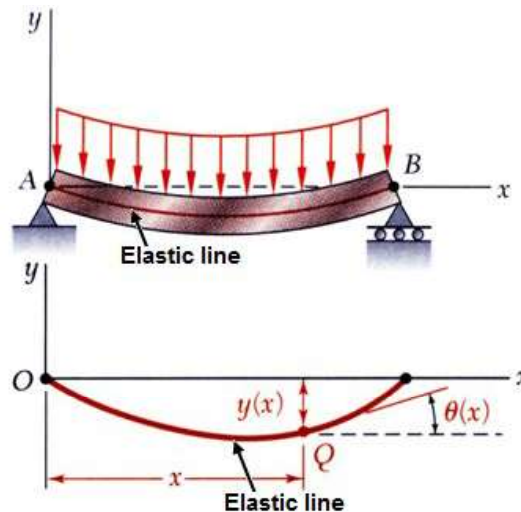
- In the case of non-uniform bending of a beam, where bending moment varies from section to section, there will be shear force at each cross section which will induce shearing stresses
- Also these shearing stresses cause warping (or out-of plane distortion) of the cross section so that plane cross sections do not remain plane even after bending

### Elastic line or Elastic curve

We have to remember that the differential equation of the elastic line is

$$EI \frac{d^2 y}{dx^2} = M_x$$

**Proof:** Consider the following simply supported beam with UDL over its length.



From elementary calculus we know that curvature of a line (at point  $Q$  in figure)

$$\frac{1}{R} = \frac{\frac{d^2 y}{dx^2}}{\left\{ 1 + \left( \frac{dy}{dx} \right)^2 \right\}^{3/2}} \quad \text{where } R = \text{radius of curvature}$$

For small deflection,  $\frac{dy}{dx} \approx 0$

$$\text{or } \frac{1}{R} \approx \frac{d^2 y}{dx^2}$$



Bending stress of the beam (at point Q)

$$\sigma_x = \frac{-(M_x) \cdot y}{I}$$

From strain relation we get

$$\frac{1}{R} = -\frac{\varepsilon_x}{y} \text{ and } \varepsilon_x = -\frac{\sigma_x}{E}$$

$$\therefore \frac{1}{R} = \frac{M_x}{EI}$$

$$\text{Therefore } \frac{d^2y}{dx^2} = \frac{M_x}{EI}$$

$$\text{or } EI \frac{d^2y}{dx^2} = M_x$$

### General expression

From the equation  $EI \frac{d^2y}{dx^2} = M_x$  we may easily find out the following relations.

- $EI \frac{d^4y}{dx^4} = -\omega$  Shear force density (Load)
- $EI \frac{d^3y}{dx^3} = V_x$  Shear force
- $EI \frac{d^2y}{dx^2} = M_x$  Bending moment
- $\frac{dy}{dx} = \theta = \text{slope}$
- $y = \delta = \text{Deflection, Displacement}$
- Flexural rigidity =  $EI$

### Double integration method (*without* the use of singularity functions)

- $V_x = \int -\omega dx$
- $M_x = \int V_x dx$
- $EI \frac{d^2y}{dx^2} = M_x$
- $\theta = \text{Slope} = \frac{1}{EI} \int M_x dx$
- $\delta = \text{Deflection} = \int \theta dx$

### 4-step procedure to solve deflection of beam problems by double integration method

**Step 1:** Write down boundary conditions (Slope boundary conditions and displacement boundary conditions), analyze the problem to be solved

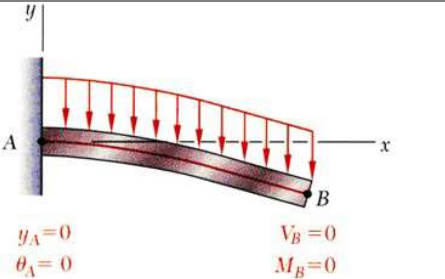
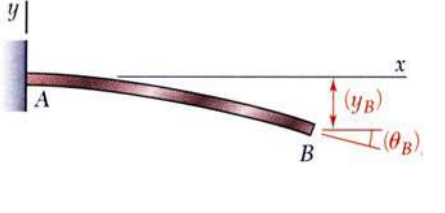
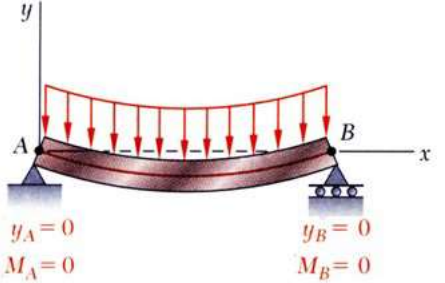
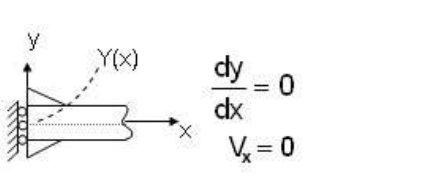
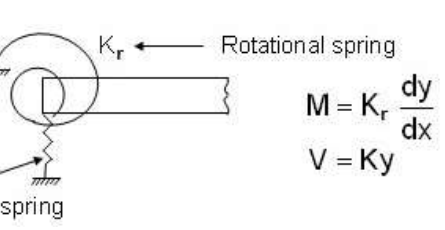
**Step 2:** Write governing equations for,  $EI \frac{d^2y}{dx^2} = M_x$

**Step 3:** Solve governing equations by integration, results in expression with unknown integration constants

**Step 4:** Apply boundary conditions (determine integration constants)



Following table gives boundary conditions for different types of support.

Types of support and Boundary Conditions	Figure
<p><b>Clamped or Built in support or Fixed end :</b> ( Point A) Deflection, <math>(y) = 0</math> Slope, <math>(\theta) = 0</math> Moment, <math>(M) \neq 0</math> i.e. A finite value</p>	 <p><math>y_A = 0</math>                      <math>V_B = 0</math> <math>\theta_A = 0</math>                      <math>M_B = 0</math></p>
<p><b>Free end: (Point B)</b> Deflection, <math>(y) \neq 0</math> i.e. A finite value Slope, <math>(\theta) \neq 0</math> i.e. A finite value Moment, <math>(M) = 0</math></p>	 <p><math>(y_B)</math> <math>(\theta_B)</math></p>
<p><b>Roller (Point B) or Pinned Support (Point A) or Hinged or Simply supported.</b> Deflection, <math>(y) = 0</math> Slope, <math>(\theta) \neq 0</math> i.e. A finite value Moment, <math>(M) = 0</math></p>	 <p><math>y_A = 0</math>                      <math>y_B = 0</math> <math>M_A = 0</math>                      <math>M_B = 0</math></p>
<p><b>End restrained against rotation but free to deflection</b> Deflection, <math>(y) \neq 0</math> i.e. A finite value Slope, <math>(\theta) = 0</math> Shear force, <math>(V) = 0</math></p>	 <p><math>\frac{dy}{dx} = 0</math> <math>V_x = 0</math></p>
<p><b>Flexible support</b> Deflection, <math>(y) \neq 0</math> i.e. A finite value Slope, <math>(\theta) \neq 0</math> i.e. A finite value Moment, <math>(M) = k_r \frac{dy}{dx}</math> Shear force, <math>(V) = k \cdot y</math></p>	 <p>Rotational spring <math>K_r</math> Linear spring <math>M = K_r \frac{dy}{dx}</math> <math>V = Ky</math></p>



# Using double integration method we will find the deflection and slope of the following loaded beams one by one.

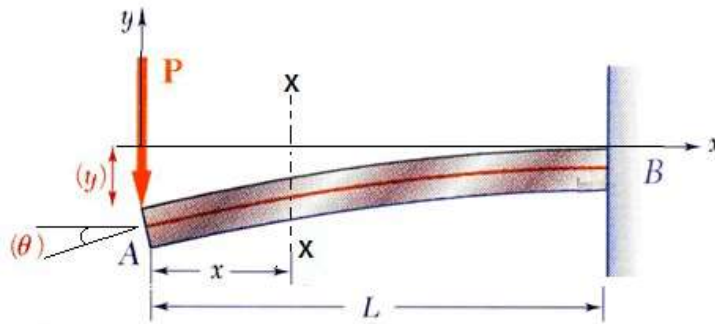
- (i) A Cantilever beam with point load at the free end.
- (ii) A Cantilever beam with UDL (uniformly distributed load)
- (iii) A Cantilever beam with an applied moment at free end.
- (iv) A simply supported beam with a point load at its midpoint.
- (v) A simply supported beam with a point load NOT at its midpoint.
- (vi) A simply supported beam with UDL (Uniformly distributed load)
- (vii) A simply supported beam with triangular distributed load (GVL) gradually varied load.
- (viii) A simply supported beam with a moment at mid span.
- (ix) A simply supported beam with a continuously distributed load the intensity of which at any

point 'x' along the beam is  $W_x = w \sin\left(\frac{\pi X}{L}\right)$

## (i) A Cantilever beam with point load at the free end.

We will solve this problem by double integration method. For that at first we have to calculate ( $M_x$ ).

Consider any section XX at a distance 'x' from free end which is left end as shown in figure.



$$\therefore M_x = -P \cdot x$$

We know that differential equation of elastic line

$$EI \frac{d^2y}{dx^2} = M_x = -P \cdot x$$

Integrating both side we get

$$\int EI \frac{d^2y}{dx^2} = -P \int x \, dx$$

$$\text{or } EI \frac{dy}{dx} = -P \cdot \frac{x^2}{2} + A \quad \dots\dots\dots(i)$$

Again integrating both side we get

$$EI \int dy = \int \left( P \frac{x^2}{2} + A \right) dx$$

$$\text{or } Ely = - \frac{Px^3}{6} + Ax + B \quad \dots\dots\dots(ii)$$

Where A and B is integration constants.

Now apply boundary condition at fixed end which is at a distance  $x = L$  from free end and we also know that at fixed end

$$\text{at } x = L, \quad y = 0$$

$$\text{at } x = L, \quad \frac{dy}{dx} = 0$$

from equation (ii)  $EIL = -\frac{PL^3}{6} + AL + B$  .....(iii)

from equation (i)  $EI.(0) = -\frac{PL^2}{2} + A$  .....(iv)

Solving (iii) & (iv) we get  $A = \frac{PL^2}{2}$  and  $B = -\frac{PL^3}{3}$

Therefore,  $y = -\frac{Px^3}{6EI} + \frac{PL^2x}{2EI} - \frac{PL^3}{3EI}$

The slope as well as the deflection would be maximum at free end hence putting  $x = 0$  we get

$y_{\max} = -\frac{PL^3}{3EI}$  (Negative sign indicates the deflection is downward)

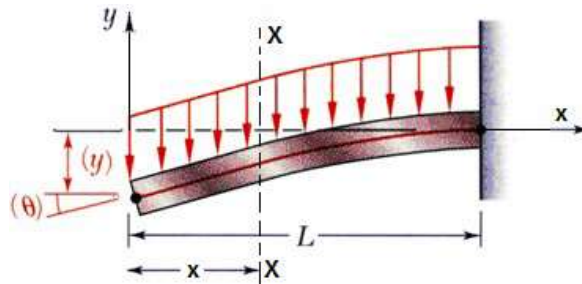
$(\text{Slope})_{\max} = \theta_{\max} = \frac{PL^2}{2EI}$

Remember for a cantilever beam with a point load at free end.

Downward deflection at free end,  $(\delta) = \frac{PL^3}{3EI}$

And slope at free end,  $(\theta) = \frac{PL^2}{2EI}$

**(ii) A Cantilever beam with UDL (uniformly distributed load)**



We will now solve this problem by double integration method, for that at first we have to calculate  $(M_x)$ .

Consider any section XX at a distance 'x' from free end which is left end as shown in figure.

$\therefore M_x = -(w \cdot x) \cdot \frac{x}{2} = -\frac{wx^2}{2}$

We know that differential equation of elastic line

$EI \frac{d^2y}{dx^2} = -\frac{wx^2}{2}$

Integrating both sides we get

$\int EI \frac{d^2y}{dx^2} = \int -\frac{wx^2}{2} dx$

or  $EI \frac{dy}{dx} = -\frac{wx^3}{6} + A$  .....(i)

Again integrating both side we get

$EI \int dy = \int \left( -\frac{wx^3}{6} + A \right) dx$

or  $EIy = -\frac{wx^4}{24} + Ax + B$ .....(ii)

[Integration constants]



Now apply boundary condition at fixed end which is at a distance  $x = L$  from free end and we also know that at fixed end.

$$\text{at } x = L, \quad y = 0$$

$$\text{at } x = L, \quad \frac{dy}{dx} = 0$$

$$\text{from equation (i) we get } EI \times (0) = \frac{-wL^3}{6} + A \text{ or } A = \frac{+wL^3}{6}$$

$$\text{from equation (ii) we get } EI \cdot y = -\frac{wL^4}{24} + A \cdot L + B$$

$$\text{or } B = -\frac{wL^4}{8}$$

The slope as well as the deflection would be maximum at the free end hence putting  $x = 0$ , we get

$$y_{\max} = -\frac{wL^4}{8EI} \quad [\text{Negative sign indicates the deflection is downward}]$$

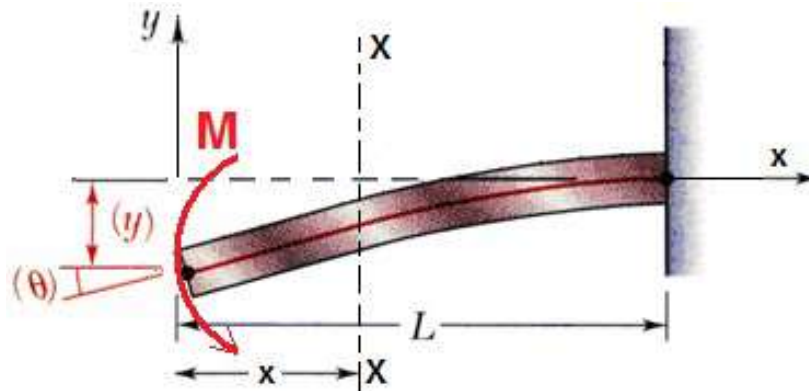
$$(\text{slope})_{\max} = \theta_{\max} = \frac{wL^3}{6EI}$$

Remember: For a cantilever beam with UDL over its whole length,

$$\text{Maximum deflection at free end } (\delta) = \frac{wL^4}{8EI}$$

$$\text{Maximum slope, } (\theta) = \frac{wL^3}{6EI}$$

**(iii) A Cantilever beam of length 'L' with an applied moment 'M' at free end.**



Consider a section XX at a distance 'x' from free end, the bending moment at section XX is

$$(M_x) = -M$$

We know that differential equation of elastic line

$$\text{or } EI \frac{d^2y}{dx^2} = -M$$

Integrating both side we get

$$\text{or } EI \int \frac{d^2y}{dx^2} = -\int M \, dx$$

$$\text{or } EI \frac{dy}{dx} = -Mx + A \dots (i)$$

Again integrating both side we get

$$EI \int dy = \int (Mx + A) dx$$

$$\text{or } EI y = -\frac{Mx^2}{2} + Ax + B \dots(ii)$$

Where A and B are integration constants.

applying boundary conditions in equation (i) & (ii)

$$\text{at } x = L, \frac{dy}{dx} = 0 \text{ gives } A = ML$$

$$\text{at } x = L, y = 0 \text{ gives } B = \frac{ML^2}{2} - ML^2 = -\frac{ML^2}{2}$$

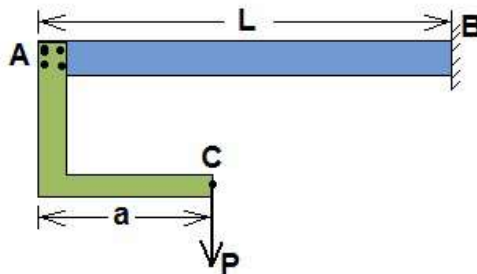
$$\text{Therefore deflection equation is } y = -\frac{Mx^2}{2EI} + \frac{MLx}{EI} - \frac{ML^2}{2EI}$$

Which is the equation of elastic curve.

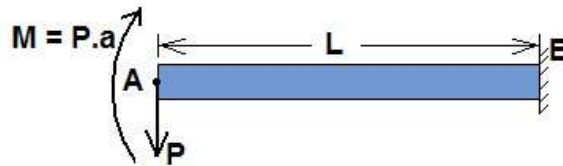
$$\therefore \text{Maximum deflection at free end } (\delta) = \frac{ML^2}{2EI} \quad (\text{It is downward})$$

$$\therefore \text{Maximum slope at free end } (\theta) = \frac{ML}{EI}$$

**Let us take a funny example:** A cantilever beam AB of length 'L' and uniform flexural rigidity EI has a bracket BA (attached to its free end. A vertical downward force P is applied to free end C of the bracket. Find the ratio a/L required in order that the deflection of point A is zero.



We may consider this force 'P' and a moment (P.a) act on free end A of the cantilever beam.



$$\text{Due to point load 'P' at free end 'A' downward deflection } (\delta) = \frac{PL^3}{3EI}$$

$$\text{Due to moment } M = P.a \text{ at free end 'A' upward deflection } (\delta) = \frac{ML^2}{2EI} = \frac{(P.a)L^2}{2EI}$$

For zero deflection of free end A

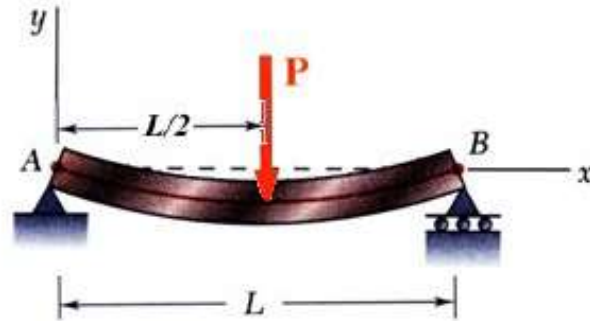
$$\frac{PL^3}{3EI} = \frac{(P.a)L^2}{2EI}$$

$$\text{or } \frac{a}{L} = \frac{2}{3}$$



**(iv) A simply supported beam with a point load P at its midpoint.**

A simply supported beam AB carries a concentrated load P at its midpoint as shown in the figure.



We want to locate the point of maximum deflection on the elastic curve and find its value.

**In the region  $0 < x < L/2$**

Bending moment at any point x (According to the shown co-ordinate system)

$$M_x = \left(\frac{P}{2}\right) \cdot x$$

and **In the region  $L/2 < x < L$**

$$M_x = \frac{P}{2}(x - L/2)$$

We know that differential equation of elastic line

$$EI \frac{d^2y}{dx^2} = \frac{P}{2} \cdot x \quad (\text{In the region } 0 < x < L/2)$$

Integrating both side we get

$$\text{or } EI \int \frac{d^2y}{dx^2} = \int \frac{P}{2} x dx$$

$$\text{or } EI \frac{dy}{dx} = \frac{P}{2} \cdot \frac{x^2}{2} + A \quad (i)$$

Again integrating both side we get

$$EI \int dy = \int \left( \frac{P}{4} x^2 + A \right) dx$$

$$\text{or } EI y = \frac{Px^3}{12} + Ax + B \quad (ii)$$

[Where A and B are integrating constants]

Now applying boundary conditions to equation (i) and (ii) we get

$$\text{at } x = 0, \quad y = 0$$

$$\text{at } x = L/2, \quad \frac{dy}{dx} = 0$$

$$A = -\frac{PL^2}{16} \quad \text{and } B = 0$$

$$\therefore \text{Equation of elastic line, } y = \frac{Px^3}{12} - \frac{PL^2}{16} x$$

Maximum deflection at mid span ( $x = L/2$ )

$$(\delta) = \frac{PL^3}{48EI}$$

and maximum slope at each end

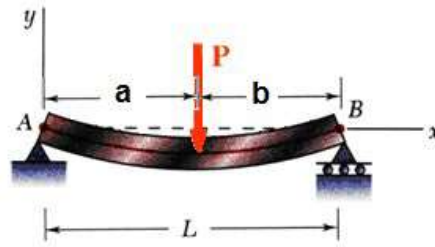
$$(\theta) = \frac{PL^2}{16EI}$$





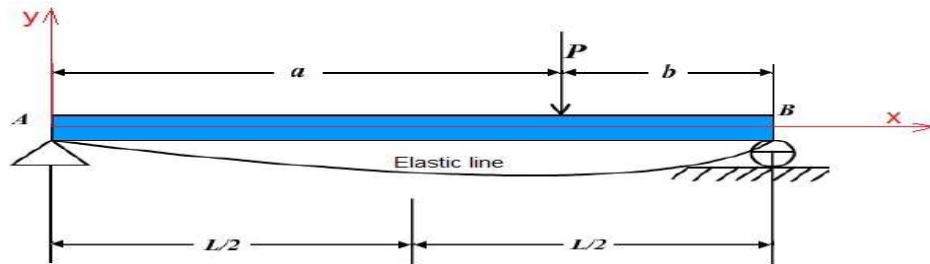
**(v) A simply supported beam with a point load 'P' NOT at its midpoint.**

A simply supported beam AB carries a concentrated load P as shown in the figure.



We have to locate the point of maximum deflection on the elastic curve and find the value of this deflection.

Taking co-ordinate axes x and y as shown below



For the bending moment we have

In the region  $0 \leq x \leq a$ ,  $M_x = \left(\frac{P \cdot a}{L}\right) \cdot x$

And, In the region  $a \leq x \leq L$ ,  $M_x = -\frac{P \cdot a}{L} (L - x)$

So we obtain two differential equation for the elastic curve.

$$EI \frac{d^2y}{dx^2} = \frac{P \cdot a}{L} \cdot x \quad \text{for } 0 \leq x \leq a$$

$$\text{and } EI \frac{d^2y}{dx^2} = -\frac{P \cdot a}{L} \cdot (L - x) \quad \text{for } a \leq x \leq L$$

Successive integration of these equations gives

$$EI \frac{dy}{dx} = \frac{P \cdot a}{L} \cdot \frac{x^2}{2} + A_1 \quad \dots\dots(i) \quad \text{for } 0 \leq x \leq a$$

$$EI \frac{dy}{dx} = P \cdot a \cdot x - \frac{P \cdot a}{L} x^2 + A_2 \quad \dots\dots(ii) \quad \text{for } a \leq x \leq L$$

$$EI y = \frac{P \cdot a}{L} \cdot \frac{x^3}{6} + A_1 x + B_1 \quad \dots\dots(iii) \quad \text{for } 0 \leq x \leq a$$

$$EI y = P \cdot a \cdot \frac{x^2}{2} - \frac{P \cdot a}{L} \cdot \frac{x^3}{6} + A_2 x + B_2 \quad \dots\dots(iv) \quad \text{for } a \leq x \leq L$$

Where  $A_1, A_2, B_1, B_2$  are constants of Integration.

Now we have to use Boundary conditions for finding constants:

BCs (a) at  $x = 0, y = 0$

(b) at  $x = L, y = 0$

(c) at  $x = a, \left(\frac{dy}{dx}\right) = \text{Same for equation (i) \& (ii)}$

(d) at  $x = a, y = \text{same from equation (iii) \& (iv)}$

We get  $A_1 = \frac{Pb}{6L}(L^2 - b^2); \quad A_2 = \frac{P \cdot a}{6L}(2L^2 + a^2)$

and  $B_1 = 0; \quad B_2 = Pa^3 / 6EI$

Therefore we get two equations of elastic curve

$$EI y = -\frac{Pbx}{6L}(L^2 - b^2 - x^2) \quad \dots (v) \quad \text{for } 0 \leq x \leq a$$

$$EI y = \frac{Pb}{6L} \left[ \left( \frac{L}{b} \right) (x-a)^3 + (L^2 - b^2)x - x^3 \right] \dots (vi) \quad \text{for } a \leq x \leq L$$

For  $a > b$ , the maximum deflection will occur in the left portion of the span, to which equation (v) applies.

Setting the derivative of this expression equal to zero gives

$$x = \sqrt{\frac{a(a+2b)}{3}} = \sqrt{\frac{(L-b)(L+b)}{3}} = \sqrt{\frac{L^2 - b^2}{3}}$$

at that point a horizontal tangent and hence the point of maximum deflection substituting this value of  $x$

into equation (v), we find,  $y_{\max} = \frac{P \cdot b(L^2 - b^2)^{3/2}}{9\sqrt{3} \cdot EIL}$

**Case -I:** if  $a = b = L/2$  then

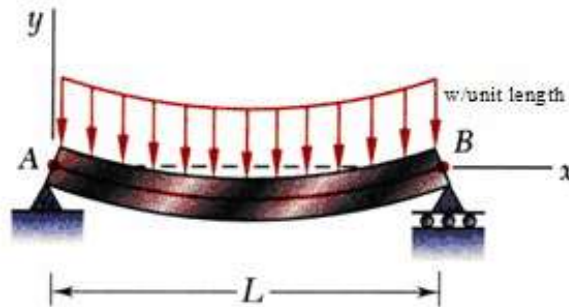
$$\text{Maximum deflection will be at } x = \sqrt{\frac{L^2 - (L/2)^2}{3}} = L/2$$

i.e. at mid point

$$\text{and } y_{\max} = (\delta) = \frac{P \cdot (L/2) \times \{L^2 - (L/2)^2\}^{3/2}}{9\sqrt{3} EIL} = \frac{PL^3}{48EI}$$

### (vi) A simply supported beam with UDL (Uniformly distributed load)

A simply supported beam AB carries a uniformly distributed load (UDL) of intensity  $w$ /unit length over its whole span  $L$  as shown in figure. We want to develop the equation of the elastic curve and find the maximum deflection  $\delta$  at the middle of the span.



Taking co-ordinate axes  $x$  and  $y$  as shown, we have for the bending moment at any point  $x$

$$M_x = \frac{wL}{2} \cdot x - w \cdot \frac{x^2}{2}$$

Then the differential equation of deflection becomes

$$EI \frac{d^2y}{dx^2} = M_x = \frac{wL}{2} \cdot x - w \cdot \frac{x^2}{2}$$

Integrating both sides we get

$$EI \frac{dy}{dx} = \frac{wL}{2} \cdot \frac{x^2}{2} - \frac{w}{2} \cdot \frac{x^3}{3} + A \quad \dots (i)$$

Again Integrating both side we get

$$EI y = \frac{wL}{2} \cdot \frac{x^3}{6} - \frac{w}{2} \cdot \frac{x^4}{12} + Ax + B \quad \dots (ii)$$

Where  $A$  and  $B$  are integration constants. To evaluate these constants we have to use boundary conditions.

at  $x = 0, y = 0$  gives  $B = 0$

at  $x = L/2, \frac{dy}{dx} = 0$  gives  $A = -\frac{wL^3}{24}$

Therefore the equation of the elastic curve

$$y = \frac{wL}{24EI} \cdot x \left[ L^3 - 2Lx^2 + x^3 \right]$$



The maximum deflection at the mid-span, we have to put  $x = L/2$  in the equation and obtain

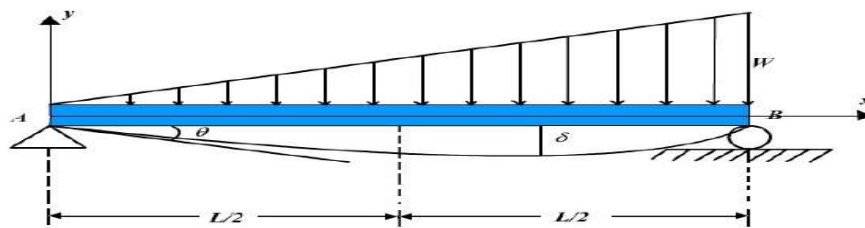
Maximum deflection at mid-span, 
$$\left(\delta\right) = \frac{5wL^4}{384EI}$$
 (It is downward)

And Maximum slope  $\theta_A = \theta_B$  at the left end A and at the right end b is same putting  $x = 0$  or  $x = L$  Therefore

we get Maximum slope 
$$\left(\theta\right) = \frac{wL^3}{24EI}$$

**(vii) A simply supported beam with triangular distributed load (GVL) gradually varied load.**

A simply supported beam carries a triangular distributed load (GVL) as shown in figure below. We have to find equation of elastic curve and find maximum deflection ( $\delta$ ).



In this (GVL) condition, we get

$$EI \frac{d^4y}{dx^4} = load = -\frac{w}{L} \cdot x \quad \dots(i)$$

Separating variables and integrating we get

$$EI \frac{d^3y}{dx^3} = (V_x) = -\frac{wx^2}{2L} + A \quad \dots(ii)$$

Again integrating thrice we get

$$EI \frac{d^2y}{dx^2} = M_x = -\frac{wx^3}{6L} + Ax + B \quad \dots(iii)$$

$$EI \frac{dy}{dx} = -\frac{wx^4}{24L} + \frac{Ax^2}{2} + Bx + C \quad \dots(iv)$$

$$EI y = -\frac{wx^5}{120L} + \frac{Ax^3}{6} + \frac{Bx^2}{2} + Cx + D \quad \dots(v)$$

Where A, B, C and D are integration constant.

Boundary conditions at  $x = 0$ ,  $M_x = 0$ ,  $y = 0$   
 at  $x = L$ ,  $M_x = 0$ ,  $y = 0$  gives

$$A = \frac{wL}{6}, B = 0, C = -\frac{7wL^3}{360}, D = 0$$

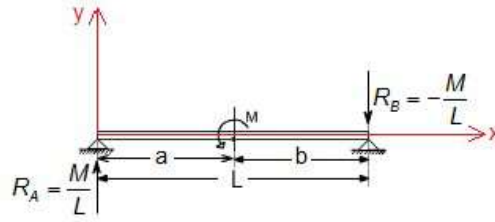
Therefore 
$$y = -\frac{wx}{360EIL} \{7L^4 - 10L^2x^2 + 3x^4\}$$
 (negative sign indicates downward deflection)

To find maximum deflection  $\delta$ , we have  $\frac{dy}{dx} = 0$

And it gives  $x = 0.519 L$  and maximum deflection  $(\delta) = 0.00652 \frac{wL^4}{EI}$

**(viii) A simply supported beam with a moment at mid-span**

A simply supported beam AB is acted upon by a couple M applied at an intermediate point distance 'a' from the equation of elastic curve and deflection at point where the moment acted.



Considering equilibrium we get  $R_A = \frac{M}{L}$  and  $R_B = -\frac{M}{L}$

Taking co-ordinate axes x and y as shown, we have for bending moment

In the region  $0 \leq x \leq a$ ,  $M_x = \frac{M}{L} \cdot x$

In the region  $a \leq x \leq L$ ,  $M_x = \frac{M}{L} \cdot x - M$

So we obtain the difference equation for the elastic curve

for  $0 \leq x \leq a$

$$EI \frac{d^2y}{dx^2} = \frac{M}{L} \cdot x$$

and  $EI \frac{d^2y}{dx^2} = \frac{M}{L} \cdot x - M$  for  $a \leq x \leq L$

Successive integration of these equation gives

$$EI \frac{dy}{dx} = \frac{M}{L} \cdot \frac{x^2}{2} + A_1 \quad \dots(i) \quad \text{for } 0 \leq x \leq a$$

$$EI \frac{dy}{dx} = \frac{M}{L} \cdot \frac{x^2}{2} - Mx + A_2 \quad \dots(ii) \quad \text{for } a \leq x \leq L$$

and  $EI y = \frac{M}{L} \cdot \frac{x^3}{3} + A_1 x + B_1 \quad \dots(iii) \quad \text{for } 0 \leq x \leq a$

$$EI y = \frac{M}{L} \cdot \frac{x^3}{3} - \frac{Mx^2}{2} + A_2 x + B_2 \quad \dots(iv) \quad \text{for } a \leq x \leq L$$

Where  $A_1, A_2, B_1$  and  $B_2$  are integration constants.

To finding these constants boundary conditions

(a) at  $x = 0, y = 0$

(b) at  $x = L, y = 0$

(c) at  $x = a, \left(\frac{dy}{dx}\right) = \text{same form equation (i) \& (ii)}$

(d) at  $x = a, y = \text{same form equation (iii) \& (iv)}$

$$A_1 = -M \cdot a + \frac{ML}{3} + \frac{Ma^2}{2L}, \quad A_2 = \frac{ML}{3} + \frac{Ma^2}{2L}$$

$$B_1 = 0, \quad B_2 = \frac{Ma^2}{2}$$

With this value we get the equation of elastic curve

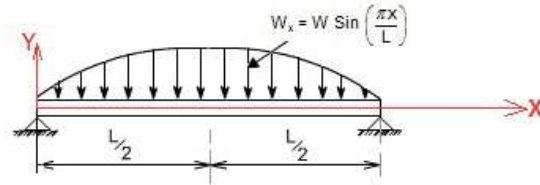
$$y = -\frac{Mx}{6L} \{6aL - 3a^2 - x^2 - 2L^2\} \quad \text{for } 0 \leq x \leq a$$

$\therefore$  deflection of  $x = a$ ,

$$y = \frac{Ma}{3EI} \{3aL - 2a^2 - L^2\}$$



(ix) A simply supported beam with a continuously distributed load the intensity of which at any point 'x' along the beam is  $w_x = w \sin\left(\frac{\pi x}{L}\right)$



At first we have to find out the bending moment at any point 'x' according to the shown co-ordinate system.

We know that

$$\frac{d(V_x)}{dx} = -w \sin\left(\frac{\pi x}{L}\right)$$

Integrating both sides we get

$$\int d(V_x) = -\int w \sin\left(\frac{\pi x}{L}\right) dx + A$$

$$\text{or } V_x = +\frac{wL}{\pi} \cdot \cos\left(\frac{\pi x}{L}\right) + A$$

and we also know that

$$\frac{d(M_x)}{dx} = V_x = \frac{wL}{\pi} \cos\left(\frac{\pi x}{L}\right) + A$$

Again integrating both sides we get

$$\int d(M_x) = \int \left\{ \frac{wL}{\pi} \cos\left(\frac{\pi x}{L}\right) + A \right\} dx$$

$$\text{or } M_x = \frac{wL^2}{\pi^2} \sin\left(\frac{\pi x}{L}\right) + Ax + B$$

Where A and B are integration constants, to find out the values of A and B. We have to use boundary conditions

$$\text{at } x = 0, \quad M_x = 0$$

$$\text{and at } x = L, \quad M_x = 0$$

From these we get  $A = B = 0$ . Therefore  $M_x = \frac{wL^2}{\pi^2} \sin\left(\frac{\pi x}{L}\right)$

So the differential equation of elastic curve

$$EI \frac{d^2y}{dx^2} = M_x = \frac{wL^2}{\pi^2} \sin\left(\frac{\pi x}{L}\right)$$

Successive integration gives

$$EI \frac{dy}{dx} = -\frac{wL^3}{\pi^3} \cos\left(\frac{\pi x}{L}\right) + C \quad \dots\dots(i)$$

$$EI y = -\frac{wL^4}{\pi^4} \sin\left(\frac{\pi x}{L}\right) + Cx + D \quad \dots\dots(ii)$$

Where C and D are integration constants, to find out C and D we have to use boundary conditions

$$\text{at } x = 0, \quad y = 0$$

$$\text{at } x = L, \quad y = 0$$

and that give  $C = D = 0$

Therefore slope equation  $EI \frac{dy}{dx} = -\frac{wL^3}{\pi^3} \cos\left(\frac{\pi x}{L}\right)$

and Equation of elastic curve  $y = -\frac{wL^4}{\pi^4 EI} \sin\left(\frac{\pi x}{L}\right)$

(-ive sign indicates deflection is downward)

Deflection will be maximum if  $\sin\left(\frac{\pi x}{L}\right)$  is maximum



$$\sin\left(\frac{\pi x}{L}\right) = 1 \quad \text{or} \quad x = L/2$$

and Maximum downward deflection ( $\delta$ ) =  $\frac{WL^4}{\pi^4 EI}$  (downward).

### Macaulay's Method

- When the beam is subjected to point loads (but several loads) this is very convenient method for determining the deflection of the beam.
- In this method we will write single moment equation in such a way that it becomes continuous for entire length of the beam in spite of the discontinuity of loading.
- After integrating this equation we will find the integration constants which are valid for entire length of the beam. This method is known as *method of singularity constant*.

### Procedure to solve the problem by Macaulay's method

**Step – I:** Calculate all reactions and moments

**Step – II:** Write down the moment equation which is valid for all values of x. This must contain brackets.

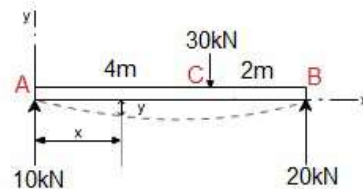
**Step – III:** Integrate the moment equation by a typical manner. Integration of (x-a) will be

$$\frac{(x-a)^2}{2} \text{ not } \left(\frac{x^2}{2} - ax\right) \text{ and integration of } (x-a)^2 \text{ will be } \frac{(x-a)^3}{3} \text{ so on.}$$

**Step – IV:** After first integration write the first integration constant (A) after first terms and after second time integration write the second integration constant (B) after A.x . Constant A and B are valid for all values of x.

**Step – V:** Using Boundary condition find A and B at a point x = p if any term in Macaulay's method, (x-a) is negative (-ive) the term will be neglected.

**(i) Let us take an example:** A simply supported beam AB length 6m with a point load of 30 kN is applied at a distance 4m from left end A. Determine the equations of the elastic curve between each change of load point and the maximum deflection of the beam.



**Answer:** We solve this problem using Macaulay's method, for that first writes the general momentum equation for the last portion of beam BC of the loaded beam.

$$EI \frac{d^2 y}{dx^2} = M_x = 10x - 30(x - 4) \quad \text{N.m} \quad \dots(i)$$

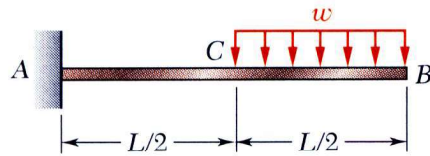
By successive integration of this equation (using Macaulay's integration rule

$$\text{e.g. } \int (x - a) dx = \frac{(x - a)^2}{2}$$

We get

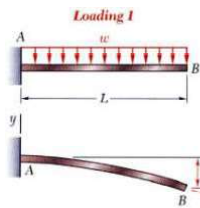
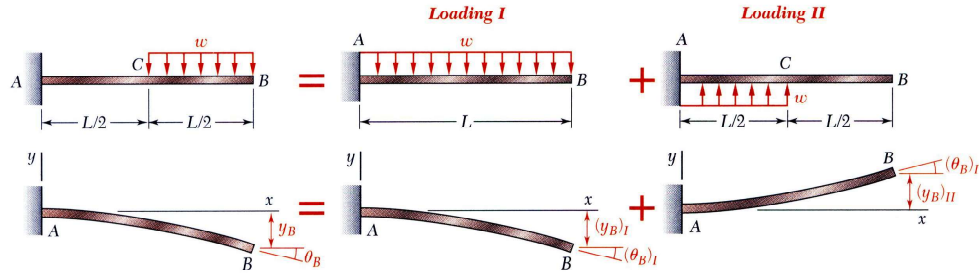


**Example:**



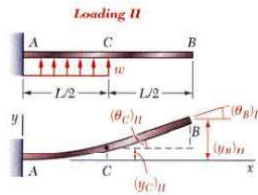
For the beam and loading shown, determine the slope and deflection at point B.

Superpose the deformations due to *Loading I* and *Loading II* as shown.



*Loading I*

$$(\theta_B)_I = -\frac{wL^3}{6EI} \quad (y_B)_I = -\frac{wL^4}{8EI}$$



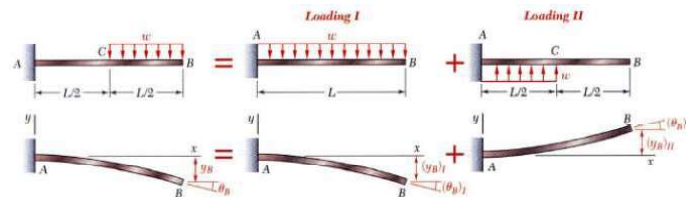
*Loading II*

$$(\theta_C)_II = \frac{wL^3}{48EI} \quad (y_C)_II = \frac{wL^4}{128EI}$$

In beam segment CB, the bending moment is zero and the elastic curve is a straight line.

$$(\theta_B)_II = (\theta_C)_II = \frac{wL^3}{48EI}$$

$$(y_B)_II = \frac{wL^4}{128EI} + \frac{wL^3}{48EI} \left(\frac{L}{2}\right) = \frac{7wL^4}{384EI}$$



Combine the two solutions.

$$\theta_B = (\theta_B)_I + (\theta_B)_II = -\frac{wL^3}{6EI} + \frac{wL^3}{48EI} \quad \theta_B = \frac{7wL^3}{48EI}$$

$$y_B = (y_B)_I + (y_B)_II = -\frac{wL^4}{8EI} + \frac{7wL^4}{384EI} \quad y_B = \frac{41wL^4}{384EI}$$



## Tutorial Questions

1. A cantilever 3m long has moment of inertia  $800 \text{ Cm}^4$  for 1m length from the free end,  $1600 \text{ cm}^4$  for the next 1m length  $2400 \text{ Cm}^4$  for the last 1m. length. At the free end a load of 1 KN acts on the cantilever. Determine the slope and deflections at the free end of the cantilever  $E= 210 \text{ GN/ m}^2$
2. A simply supported beam of span 6m carries two point loads of 60KN and 50KN at 1m and 3m respectively from the left end. Find the position and magnitude of max. deflection. Take  $E=$  as 200 GPa and  $I = 8500 \text{ cm}^4$ . Also determine the value of deflection at the same point if one more load of 60KN is placed over the left support.
3. A beam AB of 8 m span is simply supported at the ends. It carries a point load of 10 kN at a distance of 1 m from the end A and a uniformly distributed load of 5 kN/m for a length of 2 m from the end B. If  $I = 10 \times 10^6 \text{ m}^4$ , Using Macaulay's Method, Determine:
  - (a) Deection at the mid-span,
  - (b) Maximum deection, and
  - (c) Slope at the end A.
4. A simply supported beam of span 6m carries two point loads of 60KN and 50KN at 1m and 3m respectively from the left end. Find the position and magnitude of max. deflection. Take  $E=$  as 200 GPa and  $I = 8500 \text{ cm}^4$ . Also determine the value of deflection at the same point if one more load of 60KN is placed over the left support.
5. A simply supported beam of 8m carries a partial u d l of intensity 5KN/m and length 2m, sartin from 2m from the left end. Find slope at left support and central deflection. Take  $E= 200 \text{ Gpa}$  and  $I = 8 \times 10^8 \text{ mm}^4$





## Assignment Questions

1. A simply supported beam of 8m carries a partial u d l of intensity 5KN/m and length 2m, starting from 2m from the left end. Find slope at left support and central deflection. Take  $E=200\text{Gpa}$  and  $I=8\times 10^8\text{mm}^4$
2. A simply supported beam span 14m, carrying concentrated loads of 12KN and 8KN at two points 3mts and 4.5m from the two ends respectively. Moment of Inertia  $I$  for the beam is  $160\times 10^3\text{mm}^4$  and  $E = 210\text{KN/mm}^2$ . Calculate deflection of the beam at points under the two loads by macaulay's method
3. A Cantilever beam AB 6 mts long is subjected to u.d.l of  $w$  KN/m spread over the entire length. Assume rectangular cross-section with depth equal to twice the breadth. Determine the minimum dimension of the beam so that the vertical deflection at free end does not exceed 1.5 cm and the maximum stress due to bending does not exceed  $10\text{KN/cm}^2$ .  $E = 2\times 10^7\text{N/cm}^2$ .
4. A beam section is 10m long and is simply supported at ends. It carries concentrated loads of 100kN and 60kN at a distance of 2m and 5m respectively from the left end. Calculate the deflection under the each load find also the maximum deflection. Take  $I = 18\times 10^8\text{mm}^4$  and  $E = 200\text{kN/mm}^2$ .
5. A simply supported beam of span 6m carries two point loads of 60KN and 50KN at 1m and 3m respectively from the left end. Find the position and magnitude of max. deflection. Take  $E= 200\text{GPa}$  and  $I = 8500\text{cm}^4$ . Also determine the value of deflection at the same point if one more load of 60KN is placed over the left support.



---

## **UNIT 5**

# **TORSION OF CIRCULAR SHAFTS & THIN CYLINDERS**

---

**Course Objectives:**

- To analyze the cylindrical shells under circumferential and radial loading

**Course Outcomes:**

- Analyze the thin cylindrical shells.

# Unit v

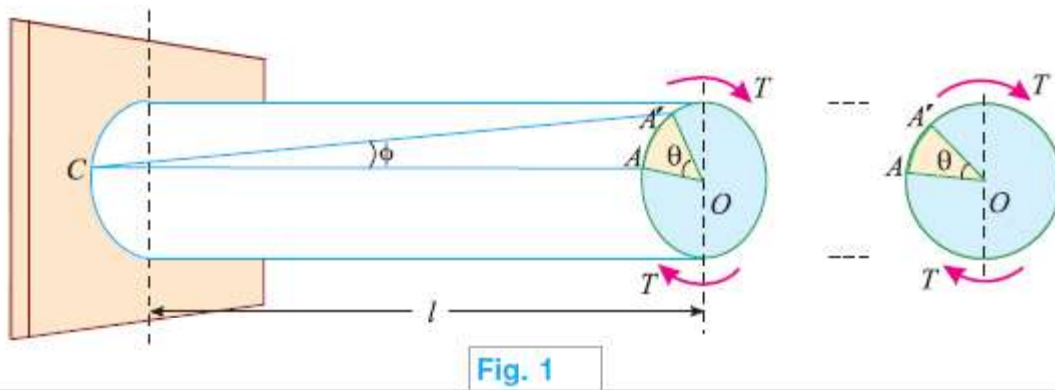
## Torsion of Circular Shafts

The product of this turning force and the distance between the point of application of the force and the axis of the shaft is known as torque, turning moment or twisting moment. And the shaft is said to be subjected to torsion. Due to this torque, every cross-section of the shaft is subjected to some shear stress.

Assumptions for Shear Stress in a Circular Shaft Subjected to Torsion

1. The material of the shaft is uniform throughout.
2. The twist along the shaft is uniform.
3. Normal cross-sections of the shaft, which were plane and circular before the twist, remain plane and circular even after the twist.
4. All diameters of the normal cross-section, which were straight before the twist, remain straight with their magnitude unchanged, after the twist.

Torsional Stresses and Strain



Consider a circular shaft fixed at one end and subjected to a torque at the other end as shown in Fig.1

$T$  = Torque in N-mm,

$l$  = Length of the shaft in mm and

$R$  = Radius of the circular shaft in mm.

As a result of this torque, every cross-section of the shaft will be subjected to shear stresses. Let the line  $CA$  on the surface of the shaft be deformed to  $CA'$  and  $OA$  to  $OA'$  as shown in Fig.1

$\angle ACA' = \phi$  in degrees

$\angle AOA' = \theta$  in radians

$\tau$  = Shear stress induced at the surface and

$C$  = Modulus of rigidity, also known as torsional rigidity of the shaft material.

We know that shear strain = Deformation per unit length

$$= \frac{AA'}{l} = \tan \theta$$

$$= \phi$$

...( $\phi$  being very small,  $\tan \phi = \phi$ )

We also know that the arc  $AA' = R \cdot \theta$

$$\therefore \phi = \frac{AA'}{l} = \frac{R \cdot \theta}{l} \quad \dots(i)$$

If  $\tau$  is the intensity of shear stress on the outermost layer and  $C$  the modulus of rigidity of the shaft, then

$$\phi = \frac{\tau}{C} \quad \dots(ii)$$

From equations (i) and (ii), we find that

$$\frac{\tau}{C} = \frac{R \cdot \theta}{l} \quad \text{or} \quad \frac{\tau}{R} = \frac{C \cdot \theta}{l}$$

If  $\tau_x$  be the intensity of shear stress, on any layer at a distance  $x$  from the centre of the shaft, then

$$\frac{\tau_x}{x} = \frac{\tau}{R} = \frac{C \cdot \theta}{l} \quad \dots(iii)$$

## Strength of a Solid Shaft

The term, strength of a shaft means the maximum torque or power, it can transmit. As a matter of fact, we are always interested in calculating the torque, a shaft can withstand or transmit.

Let

$R$  = Radius of the shaft in mm and

$\tau$  = Shear stress developed in the outermost layer of the shaft in  $\text{N/mm}^2$

Consider a shaft subjected to a torque  $T$  as shown in Fig. 2. Now let us consider an element of area  $da$  of thickness  $dx$  at a distance  $x$  from the centre of the shaft as shown in Fig. 2.

$$\therefore da = 2\pi x \cdot dx \quad \dots(i)$$

and shear stress at this section,

$$\therefore \tau_x = \tau \times \frac{x}{R} \quad \dots(ii)$$



where  $\tau$  = Maximum shear stress.

$$\begin{aligned} \therefore \text{Turning force} &= \text{Shear Stress} \times \text{Area} \\ &= \tau_x \cdot dx \\ &= \tau \times \frac{x}{R} \times da \\ &= \tau \frac{x}{R} \times 2\pi x \cdot dx \\ &= \frac{2\pi x}{R} \cdot x^2 dx \end{aligned}$$

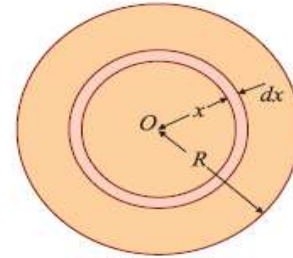


Fig. 2

We know that turning moment of this element,

$$\begin{aligned} dT &= \text{Turning force} \times \text{Distance of element from axis of the shaft} \\ &= \frac{2\pi\tau}{R} x^2 dx \cdot x = \frac{2\pi\tau}{R} x^3 \cdot dx \quad \dots(iii) \end{aligned}$$

The total torque, which the shaft can withstand, may be found out by integrating the above equation between 0 and  $R$  i.e.,

$$\begin{aligned} T &= \int_0^R \frac{2\pi\tau}{R} x^3 \cdot dx = \frac{2\pi\tau}{R} \int_0^R x^3 \cdot dx \\ &= \frac{2\pi\tau}{R} \left[ \frac{x^4}{4} \right]_0^R = \frac{\pi}{2} \tau \cdot R^3 = \frac{\pi}{16} \times \tau \times D^3 \quad \text{N-mm} \end{aligned}$$

where  $D$  is the diameter of the shaft and is equal to  $2R$ .

**EXAMPLE 1** A solid steel shaft is to transmit a torque of 10 kN-m. If the shearing stress is not to exceed 45 MPa, find the minimum diameter of the shaft.

**SOLUTION.** Given: Torque ( $T$ ) = 10 kN-m =  $10 \times 10^6$  N-mm and maximum shearing stress ( $\tau$ ) = 45 MPa = 45 N/mm<sup>2</sup>.

Let  $D$  = Minimum diameter of the shaft in mm.

We know that torque transmitted by the shaft ( $T$ ),

$$10 \times 10^6 = \frac{\pi}{16} \times \tau \times D^3 = \frac{\pi}{16} \times 45 \times D^3 = 8.836 D^3$$

$$\therefore D^3 = \frac{10 \times 10^6}{8.836} = 1.132 \times 10^6$$

$$\text{or } D = 1.04 \times 10^2 = 104 \text{ mm} \quad \text{Ans.}$$



## Strength of a Hollow Shaft

It means the maximum torque or power a hollow shaft can transmit from one pulley to another. Now consider a hollow circular shaft subjected to some torque.

Let  $R$  = Outer radius of the shaft in mm,  
 $r$  = Inner radius of the shaft in mm, and  
 $\tau$  = Maximum shear stress developed in the outer most layer of the shaft material.

Now consider an elementary ring of thickness  $dx$  at a distance  $x$  from the centre as shown in Fig. 3.

We know that area of this ring,

$$da = 2\pi x \cdot dx \quad \dots(i)$$

and shear stress at this section,

$$\tau_x = \tau \times \frac{x}{R}$$

$\therefore$  Turning force = Stress  $\times$  Area

$$= \tau_x \cdot da$$

$$\dots \left( \because \tau_x = \tau \times \frac{x}{R} \right)$$

$$= \tau \times \frac{x}{R} \times 2\pi x dx \quad \dots(\because da = 2\pi x dx)$$

$$= \frac{2\pi\tau}{R} x^2 \cdot dx \quad \dots(ii)$$

We know that turning moment of this element,

$$dT = \text{Turning force} \times \text{Distance of element from axis of the shaft}$$

$$= \frac{2\pi\tau}{R} x^2 \cdot dx \cdot x = \frac{2\pi\tau}{R} x^3 \cdot dx \quad \dots(iii)$$

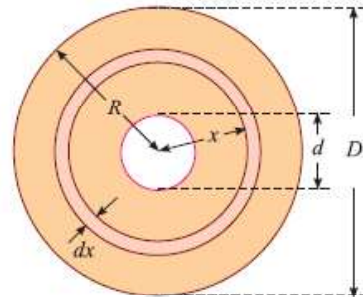


Fig. 27.3

The total torque, which the shaft can transmit, may be found out by integrating the above equation between  $r$  and  $R$ .

$$\begin{aligned} \therefore T &= \int_r^R \frac{2\pi\tau}{R} x^3 \cdot dx = \frac{2\pi\tau}{R} \int_r^R x^3 \cdot dx \\ &= \frac{2\pi\tau}{R} \left[ \frac{x^4}{4} \right]_r^R = \frac{2\pi\tau}{R} \left( \frac{R^4 - r^4}{4} \right) = \frac{\pi}{16} \times \tau \times \left( \frac{D^4 - d^4}{D} \right) \text{ N-mm} \end{aligned}$$

where  $D$  is the external diameter of the shaft and is equal to  $2R$  and  $d$  is the internal diameter of the shaft and is equal to  $2r$ .



## Power Transmitted by a Shaft

We have already discussed that the main purpose of a shaft is to transmit power from one shaft to another in factories and workshops. Now consider a rotating shaft, which transmits power from one of its ends to another.

$$\begin{aligned}\text{Let } N &= \text{No. of revolutions per minute and} \\ T &= \text{Average torque in kN-m.} \\ \text{Work done per minute} &= \text{Force} \times \text{Distance} = T \times 2\pi N = 2\pi NT \\ \text{Work done per second} &= \frac{2\pi NT}{60} \text{ kN-m} \\ \text{Power transmitted} &= \text{Work done in kN-m per second} \\ &= \frac{2\pi NT}{60} \text{ kW}\end{aligned}$$

**Example 2:** A hollow shaft is to transmit 200 kW at 80 r.p.m. If the shear stress is not to exceed 60 MPa and internal diameter is 0.6 of the external diameter, find the diameters of the shaft.

SOLUTION. Given : Power ( $P$ ) = 200 kW ; Speed of shaft ( $N$ ) = 80 r.p.m. ; Maximum shear stress ( $\tau$ ) = 60 MPa = 60 N/mm<sup>2</sup> and internal diameter of the shaft ( $d$ ) = 0.6D (where  $D$  is the external diameter in mm).

We know that torque transmitted by the shaft,

$$\begin{aligned}T &= \frac{\pi}{16} \times \tau \times \left[ \frac{D^4 - d^4}{D} \right] = \frac{\pi}{16} \times 60 \times \left[ \frac{D^4 - (0.6D)^4}{D} \right] \text{ N-mm} \\ &= 10.3 D^3 \text{ N-mm} = 10.3 \times 10^{-6} D^3 \text{ kN-m} \quad \dots(i)\end{aligned}$$

We also know that power transmitted by the shaft ( $P$ ),

$$200 = \frac{2\pi NT}{60} = \frac{2\pi \times 80 \times (10.3 \times 10^{-6} D^3)}{60} = 86.3 \times 10^{-6} D^3$$

$$\therefore D^3 = \frac{200}{(86.3 \times 10^{-6})} = 2.32 \times 10^6 \text{ mm}^3$$

$$\text{or } D = 1.32 \times 10^2 = 132 \text{ mm} \quad \text{Ans.}$$

$$\text{and } d = 0.6 D = 0.6 \times 132 = 79.2 \text{ mm} \quad \text{Ans.}$$





## Polar Moment of Inertia

The moment of inertia of a plane area, with respect to an axis perpendicular to the plane of the figure, is called polar moment of inertia with respect to the point, where the axis intersects the plane. In a circular plane, this point is always the centre of the circle. We know that

$$\frac{\tau}{R} = \frac{C \cdot \theta}{l} \quad \dots(i) \quad \dots \text{(from Art. 27.3)}$$

and 
$$T = \frac{\pi}{16} \times \tau \times D^3 \quad \dots(ii) \quad \dots \text{(from Art. 27.3)}$$

or 
$$\tau = \frac{16T}{\pi D^3}$$

Substituting the value of  $\tau$  in equation (i),

$$\frac{16T}{\pi D^3 \times R} = \frac{C \cdot \theta}{l}$$

or 
$$\frac{T}{\frac{\pi}{16} \times D^3 \times R} = \frac{C \cdot \theta}{l}$$

$$\frac{T}{\frac{\pi}{32} \times D^4} = \frac{C \cdot \theta}{l} \quad \dots \left( \text{Radius, } R = \frac{D}{2} \right)$$

$$\frac{T}{J} = \frac{C \cdot \theta}{l} \quad \dots(iii)$$

where  $J = \frac{\pi}{32} \times D^4$ . It is known as polar moment of inertia.

The above equation (iii) may also be written as :

$$\frac{\tau}{R} = \frac{T}{J} = \frac{C \cdot \theta}{l} \quad \dots \left( \because \frac{\tau}{R} = \frac{C \cdot \theta}{l} \right)$$



**EXAMPLE 3.** Find the angle of twist per metre length of a hollow shaft of 100 mm external and 60 mm internal diameter, if the shear stress is not to exceed 35 MPa. Take  $C = 85$  GPa.

**SOLUTION.** Given: Length of the shaft ( $l$ ) = 1 m =  $1 \times 10^3$  mm ; External diameter ( $D$ ) = 100 mm; Internal diameter ( $d$ ) = 60 mm ; Maximum shear stress ( $\tau$ ) = 35 MPa = 35 N/mm<sup>2</sup> and modulus of rigidity ( $C$ ) = 85 GPa =  $85 \times 10^3$  N/mm<sup>2</sup>.

Let  $\theta$  = Angle of twist in the shaft.

We know that torque transmitted by the shaft,

$$\begin{aligned} T &= \frac{\pi}{16} \times \tau \times \left[ \frac{D^4 - d^4}{D} \right] = \frac{\pi}{16} \times 35 \times \left[ \frac{(100)^4 - (60)^4}{100} \right] \text{ N-mm} \\ &= 5.98 \times 10^6 \text{ N-mm} \end{aligned}$$

We also know that polar moment of inertia of a hollow circular shaft,

$$J = \frac{\pi}{32} [D^4 - d^4] = \frac{\pi}{32} [(100)^4 - (60)^4] = 8.55 \times 10^6 \text{ mm}^4$$

and relation for the angle of twist,

$$\frac{T}{J} = \frac{C \cdot \theta}{l} \quad \text{or} \quad \frac{5.98 \times 10^6}{8.55 \times 10^6} = \frac{(85 \times 10^3) \theta}{1 \times 10^3} = 85 \cdot \theta$$

$$\therefore \theta = \frac{5.98 \times 10^6}{(8.55 \times 10^6) \times 85} = 0.008 \text{ rad} = 0.5^\circ \quad \text{Ans.}$$

**EXAMPLE 4.** A solid shaft is subjected to a torque of 1.6 kN-m. Find the necessary diameter of the shaft, if the allowable shear stress is 60 MPa. The allowable twist is 1° for every 20 diameters length of the shaft. Take  $C = 80$  GPa.



**SOLUTION.** Given: Torque ( $T$ ) = 1.6 kN-m =  $1.6 \times 10^6$  N-mm; Allowable shear stress ( $\tau$ ) = 60 MPa = 60 N/mm<sup>2</sup>; Angle of twist ( $\theta$ ) =  $1^\circ = \frac{\pi}{180}$  rad; Length of shaft ( $l$ ) =  $20D$  and modulus of rigidity ( $C$ ) = 80 GPa =  $80 \times 10^3$  N/mm<sup>2</sup>.

First of all, let us find out the value of diameter of the shaft for its strength and stiffness.

**1. Diameter for strength**

We know that torque transmitted by the shaft ( $T$ ),

$$1.6 \times 10^6 = \frac{\pi}{16} \times \tau \times D_1^3 = \frac{\pi}{16} \times 60 \times D_1^3 = 11.78 D_1^3$$

$$\therefore D_1^3 = \frac{1.6 \times 10^6}{11.78} = 0.136 \times 10^6 \text{ mm}^3$$

$$\text{or } D_1 = 0.514 \times 10^2 = 51.4 \text{ mm} \quad \dots(i)$$

**2. Diameter for stiffness**

We know that polar moment of inertia of a solid circular shaft,

$$J = \frac{\pi}{32} \times (D_2)^4 = 0.098 D_2^4$$

and relation for the diameter,

$$\frac{T}{J} = \frac{C \cdot \theta}{l} \quad \text{or} \quad \frac{1.6 \times 10^6}{0.098 D_2^4} = \frac{(80 \times 10^3) \times (\pi/180)}{20D_2}$$

$$\therefore D_2^3 = \frac{(1.6 \times 10^6) \times 20}{0.098 \times (80 \times 10^3) \times (\pi/180)} = 234 \times 10^3 \text{ mm}^3$$

$$\text{or } D_2 = 6.16 \times 10^1 = 61.6 \text{ mm} \quad \dots(ii)$$

We shall provide a shaft of diameter of 61.6 mm (*i.e.*, greater of the two values). **Ans.**

**EXAMPLE 5.** A solid shaft of 200 mm diameter has the same cross-sectional area as a hollow shaft of the same material with inside diameter of 150 mm. Find the ratio of

- (a) powers transmitted by both the shafts at the same angular velocity.
- (b) angles of twist in equal lengths of these shafts, when stressed to the same intensity.

**SOLUTION.** Given: Diameter of solid shaft ( $D_1$ ) = 200 mm and inside diameter of hollow shaft ( $d$ ) = 150 mm.

**(a) Ratio of powers transmitted by both the shafts**

We know that cross-sectional area of the solid shaft,

$$A_1 = \frac{\pi}{4} \times D_1^2 = \frac{\pi}{4} \times (200)^2 = 10\,000 \pi \text{ mm}^2$$

and cross-sectional area of hollow shaft,

$$A_2 = \frac{\pi}{4} \times (D^2 - d^2) = \frac{\pi}{4} \times [D^2 - (150)^2] = \frac{\pi}{4} (D^2 - 22\,500)$$



Since the cross-sectional areas of both the shafts are same, therefore equating  $A_1$  and  $A_2$ ,

$$\begin{aligned} \frac{\pi}{4} (200)^2 &= \frac{\pi}{4} (D^2 - 22\,500) \\ \therefore 40\,000 &= D^2 - 22\,500 \\ D^2 &= 40\,000 + 22\,500 = 62\,500 \text{ mm}^2 \\ \text{or } D &= 250 \text{ mm} \end{aligned}$$

We also know that torque transmitted by the solid shaft,

$$T_1 = \frac{\pi}{16} \times \tau \times D_1^3 = \frac{\pi}{16} \times \tau \times (200)^3 = 500 \times 10^3 \pi \tau \text{ N-mm} \quad \dots(i)$$

Similarly, torque transmitted by the hollow shaft,

$$\begin{aligned} T_2 &= \frac{\pi}{16} \times \tau \times \left[ \frac{D^4 - d^4}{D} \right] = \frac{\pi}{16} \times \tau \times \left[ \frac{(250)^4 - (150)^4}{250} \right] \text{ N-mm} \\ &= 850 \times 10^3 \pi \tau \text{ N-mm} \end{aligned}$$

$$\therefore \frac{\text{Power transmitted by hollow shaft}}{\text{Power transmitted by solid shaft}}$$

$$= \frac{T_2}{T_1} = \frac{50 \times 10^3 \pi \tau}{500 \times 10^3 \pi \tau} = 1.7 \quad \text{Ans.}$$

**(b) Ratio of angles of twist in both the shafts**

We know that relation for angle of twist for a shaft,

$$\frac{\tau}{R} = \frac{C \cdot \theta}{l} \quad \text{or} \quad \theta = \frac{\tau l}{RC}$$

$\therefore$  Angle of twist for the solid shaft,

$$\theta_1 = \frac{\tau l}{RC} = \frac{\tau l}{100C} \quad \dots \left( \text{where } R = \frac{D_1}{2} = \frac{200}{2} = 100 \text{ mm} \right)$$

Similarly angle of twist for the hollow shaft,

$$\theta_2 = \frac{\tau l}{RC} = \frac{\tau l}{125C} \quad \dots \left( \text{where } R = \frac{D_1}{2} = \frac{250}{2} = 125 \text{ mm} \right)$$

$$\therefore \frac{\text{Angle of twist of hollow shaft}}{\text{Angle of twist of solid shaft}} = \frac{\theta_2}{\theta_1} = \frac{\frac{\tau l}{125C}}{\frac{\tau l}{100C}} = \frac{100}{125} = 0.8 \quad \text{Ans.}$$



**EXAMPLE 6.** A shaft ABC of 500 mm length and 40 mm external diameter is bored, for a part of its length AB to a 20 mm diameter and for the remaining length BC to a 30 mm diameter bore as shown in Fig. . If the shear stress is not to exceed 80 MPa, find the maximum power, the shaft can transmit at a speed of 200 r.p.m.

If the angle of twist in the length of 20 mm diameter bore is equal to that in the 30 mm diameter bore, find the length of the shaft that has been bored to 20 mm and 30 mm diameter.

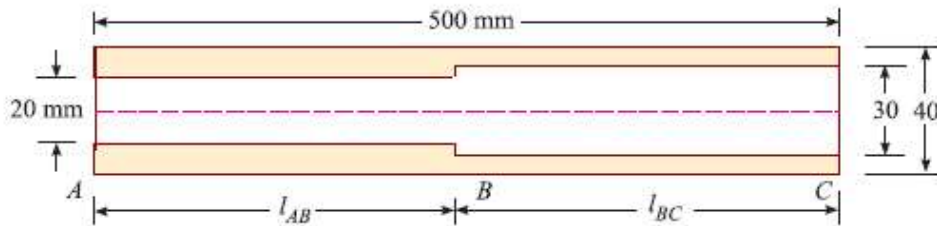


Fig.

**SOLUTION.** Given: Total length of the shaft ( $l$ ) = 500 mm; External diameter of the shaft ( $D$ ) = 40 mm ; Internal diameter of shaft AB ( $d_{AB}$ ) = 20 mm ; Internal diameter of shaft BC ( $d_{BC}$ ) = 30 mm ; Maximum shear stress ( $\tau$ ) = 80 MPa = 80 N/mm<sup>2</sup> and speed of the shaft ( $N$ ) = 200 r.p.m.

**Maximum power the shaft can transmit**

We know that torque transmitted by the shaft AB,

$$\begin{aligned} T_{AB} &= \frac{\pi}{16} \times \tau \times \left( \frac{D^4 - d_{AB}^4}{D} \right) = \frac{\pi}{16} \times 80 \times \left[ \frac{(40)^4 - (20)^4}{40} \right] \text{ N-mm} \\ &= 942.5 \times 10^3 \text{ N-mm} \quad \dots(i) \end{aligned}$$

Similarly,

$$\begin{aligned} T_{BC} &= \frac{\pi}{16} \times \tau \times \left( \frac{D^4 - d_{BC}^4}{D} \right) = \frac{\pi}{16} \times 80 \times \left[ \frac{(40)^4 - (30)^4}{40} \right] \text{ N-mm} \\ &= 687.3 \times 10^3 \text{ N-mm} \quad \dots(ii) \end{aligned}$$

From the above two values, we see that the safe torque transmitted by the shaft is minimum of the two, i.e.,  $687.3 \times 10^3 \text{ N-mm} = 687.3 \text{ N-m}$ . Therefore maximum power the shaft can transmit,

$$\begin{aligned} P &= \frac{2\pi NT}{60} = \frac{2 \times \pi \times 200 \times (687.3)}{60} = 14\,394 \text{ W} \\ &= 14.39 \text{ kW} \quad \text{Ans.} \end{aligned}$$

**Length of the shaft, that has been bored to 20 mm diameter**

Let  $l_{AB}$  = Length of the shaft AB (i.e., 20 mm diameter bore) and

$l_{BC}$  = Length of the shaft BC (i.e., 30 mm diameter bore) equal to  $(500 - l_{AB})$  mm.

We know that polar moment of inertia for the shaft AB,

$$J_{AB} = \frac{\pi}{32} \times (D^4 - d_{AB}^4) = \frac{\pi}{32} \times [(40)^4 - (20)^4] \text{ mm}^4$$

Similarly,

$$J_{BC} = \frac{\pi}{32} \times (D^4 - d_{BC}^4) = \frac{\pi}{32} \times [(40)^4 - (30)^4] \text{ mm}^4$$

We know that relation for the angle of twist:

$$\frac{T}{J} = \frac{C \theta}{l} \quad \text{or} \quad \theta = \frac{T \cdot l}{J C}$$

$$\therefore \theta_{AB} = \frac{T \cdot l_{AB}}{J_{AB} \cdot C} \quad \text{and} \quad \theta_{BC} = \frac{T \cdot l_{BC}}{J_{BC} \cdot C}$$

Since  $\theta_{AB} = \theta_{BC}$  and  $T$  as well as  $C$  is equal in both these cases, therefore

$$\frac{l_{AB}}{J_{AB}} = \frac{l_{BC}}{J_{BC}} \quad \text{or} \quad \frac{l_{AB}}{\frac{\pi}{32} \times [(40)^4 - (20)^4]} = \frac{l_{BC}}{\frac{\pi}{32} \times [(40)^4 - (30)^4]}$$

$$\text{or} \quad \frac{l_{AB}}{l_{BC}} = \frac{(40)^4 - (20)^4}{(40)^4 - (30)^4} = \frac{2400000}{1750000} = 1.37$$

$$\therefore l_{AB} = 1.37 l_{BC}$$

$$1.37 l_{BC} + l_{BC} = 500 \quad \dots (\because l_{AB} + l_{BC} = 500)$$

$$\therefore l_{BC} = \frac{500}{2.37} = 211 \text{ mm} \quad \text{Ans.}$$

$$\text{and} \quad l_{AB} = 500 - 211 = 289 \text{ mm} \quad \text{Ans.}$$



# Thin Cylinders

In general, if the thickness of the wall of a shell is less than 1/10th to 1/15th of its diameter, it is known as a thin shell.

## Stresses in a Thin Cylindrical Shell

The walls of the cylindrical shell will be subjected to the following two types of tensile stresses:

1. Circumferential stress
2. Longitudinal stress.

## Circumferential Stress

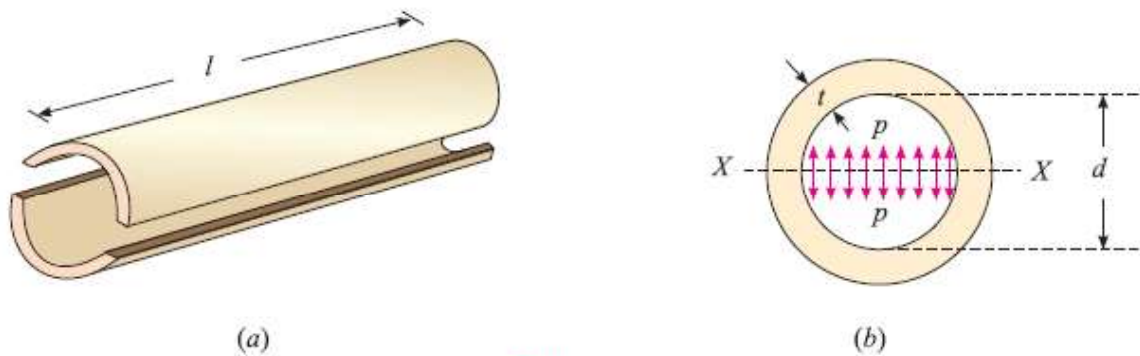


Fig.

Consider a thin cylindrical shell subjected to an internal pressure as shown in Fig.(a) and (b). We know that as a result of the internal pressure, the cylinder has a tendency to split up into two troughs as shown in the figure.

Let  $l$  = Length of the shell

$d$  = Diameter of the shell,

$t$  = Thickness of the shell and

$p$  = Intensity of internal pressure.

Total pressure along the diameter (say  $X-X$  axis) of the shell,

$$P = \text{Intensity of internal pressure} \times \text{Area} = p \times d \times l$$

and circumferential stress in the shell,

$$\sigma_c = \frac{\text{Total pressure}}{\text{Resisting section}} = \frac{pdl}{2tl} = \frac{pd}{2t} \quad \dots(\because \text{ of two sections})$$

This is a tensile stress across the  $X-X$ . It is also known as **hoop stress**.

**NOTE.** If  $\eta$  is the efficiency of the riveted joints of the shell, then stress,

$$\sigma_c = \frac{pd}{2t\eta}$$

## Longitudinal Stress

Consider the same cylindrical shell, subjected to the same internal pressure as shown in Fig. (a) and (b). We know that as a result of the internal pressure, the cylinder also has a tendency to split into two pieces as shown in the figure.

Let  $p$  = Intensity of internal pressure,

$l$  = Length of the shell,

$d$  = Diameter of the shell and

$t$  = Thickness of the shell.





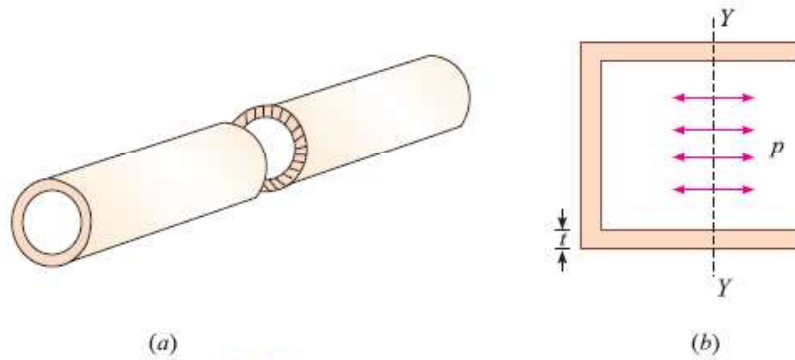


Fig. . Longitudinal stress.

Total pressure along its length (say  $Y-Y$  axis) of the shell

$$\begin{aligned}
 P &= \text{Intensity of internal pressure} \times \text{Area} \\
 &= p \times \frac{\pi}{4} (d)^2
 \end{aligned}$$

and longitudinal stress in the shell,

$$\sigma_l = \frac{\text{Total pressure}}{\text{Resisting section}} = \frac{p \times \frac{\pi}{4} (d)^2}{\pi dt} = \frac{pd}{4t}$$

This is also a tensile stress across the section  $Y-Y$ . It may be noted that the longitudinal stress is half of the circumferential or hoop stress.

**NOTE.** If  $\eta$  is the efficiency of the riveted joints of the shell, then the stress,

$$\sigma_l = \frac{pd}{4t\eta}$$

**EXAMPLE 1.** A steam boiler of 800 mm diameter is made up of 10 mm thick plates. If the boiler is subjected to an internal pressure of 2.5 MPa, find the circumferential and longitudinal stresses induced in the boiler plates.

**SOLUTION.** Given : Diameter of boiler ( $d$ ) = 800 mm ; Thickness of plates ( $t$ ) = 10 mm and internal pressure ( $p$ ) = 2.5 MPa = 2.5 N/mm<sup>2</sup>.

**Circumferential stress induced in the boiler plates**

We know that circumferential stress induced in the boiler plates,

$$\sigma_c = \frac{pd}{2t} = \frac{2.5 \times 800}{2 \times 10} = 100 \text{ N/mm}^2 = \mathbf{100 \text{ MPa}} \quad \text{Ans.}$$

**Longitudinal stress induced in the boiler plates**

We also know that longitudinal stress induced in the boiler plates,

$$\sigma_l = \frac{pd}{4t} = \frac{2.5 \times 800}{4 \times 10} = 50 \text{ N/mm}^2 = \mathbf{50 \text{ MPa}} \quad \text{Ans.}$$

**EXAMPLE 2.** A cylindrical shell of 1.3 m diameter is made up of 18 mm thick plates. Find the circumferential and longitudinal stress in the plates, if the boiler is subjected to an internal pressure of 2.4 MPa. Take efficiency of the joints as 70%.

**SOLUTION.** Given: Diameter of shell ( $d$ ) = 1.3 m =  $1.3 \times 10^3$  mm ; Thickness of plates ( $t$ ) = 18 mm; Internal pressure ( $p$ ) = 2.4 MPa = 2.4 N/mm<sup>2</sup> and efficiency ( $\eta$ ) = 70% = 0.7.

**Circumferential stress**

We know that circumferential stress,

$$\sigma_c = \frac{pd}{2t\eta} = \frac{2.4 \times (1.3 \times 10^3)}{2 \times 18 \times 0.7} = 124 \text{ N/mm}^2 = \mathbf{124 \text{ MPa}} \quad \text{Ans.}$$

**Longitudinal stress**

We also know that longitudinal stress,

$$\sigma_l = \frac{pd}{4t\eta} = \frac{2.4 \times (1.3 \times 10^3)}{4 \times 18 \times 0.7} = 62 \text{ N/mm}^2 = \mathbf{62 \text{ MPa}} \quad \text{Ans.}$$

**EXAMPLE 3.** A gas cylinder of internal diameter 40 mm is 5 mm thick. If the tensile stress in the material is not to exceed 30 MPa, find the maximum pressure which can be allowed in the cylinder.

**SOLUTION.** Given: Diameter of cylinder ( $d$ ) = 40 mm ; Thickness of plates ( $t$ ) = 5 mm and tensile stress ( $\sigma_c$ ) = 30 MPa = 30 N/mm<sup>2</sup>.

Let  $p$  = Maximum pressure which can be allowed in the cylinder.

We know that circumferential stress ( $\sigma_c$ ),

$$30 = \frac{pd}{2t} = \frac{p \times 40}{2 \times 5} = 4p$$

$$\therefore p = \frac{30}{4} = 7.5 \text{ N/mm}^2 = \mathbf{7.5 \text{ MPa}} \quad \text{Ans.}$$



## **Change in Dimensions of a Thin Cylindrical Shell due to an Internal Pressure**

Thin cylindrical shell subjected to an internal pressure, its walls will also be subjected to lateral strain. The effect of the lateral strains is to cause some change in the dimensions (i.e., length and diameter) of the shell. Now consider a thin cylindrical shell subjected to an internal pressure.

Let                     $l$  = Length of the shell,  
                               $d$  = Diameter of the shell,



$t$  = Thickness of the shell and

$p$  = Intensity of the internal pressure.

We know that the circumferential stress,

$$\sigma_c = \frac{pd}{2t}$$

and longitudinal stress,

$$\sigma_l = \frac{pd}{4t}$$

Now let

$\delta d$  = Change in diameter of the shell,

$\delta l$  = Change in the length of the shell and

$$\frac{1}{m} = \text{Poisson's ratio.}$$

Now changes in diameter and length may be found out from the above equations, as usual (*i.e.*, by multiplying the strain and the corresponding linear dimension).

$$\therefore \delta d = \epsilon_1 \cdot d = \frac{pd}{2tE} \left(1 - \frac{1}{2m}\right) \times d = \frac{pd^2}{2tE} \left(1 - \frac{1}{2m}\right)$$

$$\text{and } \delta l = \epsilon_2 \cdot l = \frac{pd}{2tE} \left(\frac{1}{2} - \frac{1}{m}\right) \times l = \frac{pdl}{2tE} \left(\frac{1}{2} - \frac{1}{m}\right)$$

**EXAMPLE 4.** A cylindrical thin drum 800 mm in diameter and 4 m long is made of 10 mm thick plates. If the drum is subjected to an internal pressure of 2.5 MPa, determine its changes in diameter and length. Take  $E$  as 200 GPa and Poisson's ratio as 0.25.

**SOLUTION.** Given: Diameter of drum ( $d$ ) = 800 mm ; Length of drum ( $l$ ) = 4 m =  $4 \times 10^3$  mm ; Thickness of plates ( $t$ ) = 10 mm ; Internal pressure ( $p$ ) = 2.5 MPa =  $2.5 \text{ N/mm}^2$  ; Modulus of elasticity ( $E$ ) = 200 GPa =  $200 \times 10^3 \text{ N/mm}^2$  and poisson's ratio  $\left(\frac{1}{m}\right) = 0.25$ .

#### Change in diameter

We know that change in diameter,

$$\begin{aligned} \delta d &= \frac{pd^2}{2tE} \left(1 - \frac{1}{2m}\right) = \frac{2.5 \times (800)^2}{2 \times 10 \times (200 \times 10^3)} \left(1 - \frac{0.25}{2}\right) \text{ mm} \\ &= 0.35 \text{ mm} \quad \text{Ans.} \end{aligned}$$

#### Change in length

We also know that change in length,

$$\begin{aligned} \delta l &= \frac{pdl}{2tE} \left(\frac{1}{2} - \frac{1}{m}\right) = \frac{2.5 \times 800 \times (4 \times 10^3)}{2 \times 10 \times (200 \times 10^3)} \left(\frac{1}{2} - 0.25\right) \text{ mm} \\ &= 0.5 \text{ mm} \quad \text{Ans.} \end{aligned}$$

### Change in Volume of a Thin Cylindrical Shell due to an Internal Pressure

A little consideration will show that increase in the length and diameter of the shell will also increase its volume. Now consider a thin cylindrical shell subjected to an internal pressure.

Let  $l$  = Original length

$d$  = Original diameter,



$\delta l$  = Change in length due to pressure and

$\delta d$  = Change in diameter due to pressure.

We know that original volume,

$$\begin{aligned} V &= \frac{\pi}{4} \times d^2 \times l = \left[ \frac{\pi}{4} (d + \delta d)^2 \times (l + \delta l) \right] - \frac{\pi}{4} \times d^2 \times l \\ &= \frac{\pi}{4} (d^2 \cdot \delta l + 2dl \cdot \delta d) \quad \dots(\text{Neglecting small quantities}) \end{aligned}$$

$$\therefore \frac{\delta V}{V} = \frac{\frac{\pi}{4} (d^2 \cdot \delta l + 2dl \cdot \delta d)}{\frac{\pi}{4} \times d^2 \times l} = \frac{\delta l}{l} + \frac{2\delta d}{d} = \epsilon_l + 2\epsilon_c$$

or  $\delta V = V (\epsilon_l + 2\epsilon_c)$   
where  $\epsilon_c$  = Circumferential strain and  
 $\epsilon_l$  = Longitudinal strain.

**EXAMPLE 5.** A cylindrical vessel 2 m long and 500 mm in diameter with 10 mm thick plates is subjected to an internal pressure of 3 MPa. Calculate the change in volume of the vessel. Take  $E = 200$  GPa and Poisson's ratio = 0.3 for the vessel material.

**SOLUTION.** Given: Length of vessel ( $l$ ) = 2 m =  $2 \times 10^3$  mm ; Diameter of vessel ( $d$ ) = 500 mm ; Thickness of plates ( $t$ ) = 10 mm ; Internal pressure ( $p$ ) = 3 MPa = 3 N/mm<sup>2</sup> ; Modulus of elasticity ( $E$ ) = 200 GPa =  $200 \times 10^3$  N/mm<sup>2</sup> and poisson's ratio  $\left(\frac{1}{m}\right) = 0.3$ .

We know that circumferential strain,

$$\epsilon_c = \frac{pd}{2tE} \left(1 - \frac{1}{2m}\right) = \frac{3 \times 500}{2 \times 10 \times (200 \times 10^3)} \left(1 - \frac{0.3}{2}\right) = 0.32 \times 10^{-3} \quad \dots(i)$$

and longitudinal strain,  $\epsilon_l = \frac{pd}{2tE} \left(\frac{1}{2} - \frac{1}{m}\right) = \frac{3 \times 500}{2 \times 10 \times (200 \times 10^3)} \left(\frac{1}{2} - 0.3\right) = 0.075 \times 10^{-3} \quad \dots(ii)$

We also know that original volume of the vessel,

$$V = \frac{\pi}{4} (d)^2 \times l = \frac{\pi}{4} (500)^2 \times (2 \times 10^3) = 392.7 \times 10^6 \text{ mm}^3$$

$\therefore$  Change in volume,

$$\begin{aligned} \delta V &= V (\epsilon_c + 2\epsilon_l) = 392.7 \times 10^6 [0.32 \times 10^{-3} + (2 \times 0.075 \times 10^{-3})] \text{ mm}^3 \\ &= 185 \times 10^3 \text{ mm}^3 \quad \text{Ans.} \end{aligned}$$



## Tutorial Questions

1. Derive an expression for the shear stress produced in a circular shaft which is subjected to torsion. What are the assumptions made in the above derivation ?
2. a) Derive the formula for the hoop stress in a thin cylindrical shell subjected to an internal pressure.  
b) A gas cylinder of thickness 25 mm and has an internal diameter of 1500 mm. The tensile stress in the gas cylinder material is not to exceed 100 N/mm<sup>2</sup>. Calculate the allowable internal pressure of the gas inside the cylinder.
3. A thin cylindrical shell is 3m long and 1m in internal diameter. It is subjected to internal pressure of 1.2 MPa. If the thickness of the shell is 12mm, find the circumferential stress, longitudinal stress, changes in diameter, length and volume. Take  $E=200$  GPa and  $\mu=0.3$ .
4. A Hollow shaft is to transmit 400 KW power at 120 rpm. If the shear stress is not exceed 60 N/mm<sup>2</sup> and internal diameter is 0.65 of external diameter. Find the internal and external diameters assuming maximum torque is 1.5 times the mean
5. A hollow shaft of diameter ratio 3/8 is to transmit 395 kW at 120 rpm. The maximum torque being 24% greater than the mean, the shear stress is not to exceed 65 MPa and the twist in a length of 6 m is not to exceed 3 degrees. Calculate its external and internal diameters which would satisfy both the above said conditions. Take  $G=9.2 \times 10^4$  MPa.



## Assignment Questions

1. A cylindrical vessel 2m long and 500mm in diameter with 10mm thick plates is subjected to an internal pressure of 3MPa. Calculate the change in volume of the vessel. Take  $E=200\text{GPa}$  and Poisson's ratio  $=0.3$  for the vessel material.
2. A shaft is to be transmitted 100KW at 240 rpm. If the allowable shear stresses of the material is 60MPa. The shaft is not to twist more than  $1^\circ$  in a length of 3.5 mts. Find the diameter of the shaft based on strength and stiffness criteria. The modulus of rigidity of the material (N) is  $80 \times 10^3 \text{N/mm}^2$ .
3. A cylindrical vessel 3m long and 500mm in diameter with 10mm thick plates is subjected to an internal pressure of 3MPa. Calculate the change in volume of the vessel. Take  $E=210\text{GPa}$  and Poisson's ratio  $=0.3$  for the vessel material.
4. A thin cylindrical shell is 3m long and 1m in internal diameter. It is subjected to internal pressure of 1.2 MPa. If the thickness of the sheet is 12mm, find the circumferential stress, longitudinal stress, changes in diameter, length and volume. Take  $E=200 \text{GPa}$  and  $\mu=0.3$ .
5. A thin cylindrical shell is 3m long and 1m in internal diameter. It is subjected to internal pressure of 1.2 MPa. If the thickness of the sheet is 12mm, find the circumferential stress, longitudinal stress, changes in diameter, length and volume. Take  $E=200 \text{GPa}$  and  $\mu=0.3$ .
6. A hollow shaft of outside diameter 80 mm and inside diameter 50 mm is made of aluminium having shear modulus  $G = 27\text{GPa}$ . When the shaft is subjected to a torque  $T = 4.8 \text{kN-m}$ , what is the maximum shear strain and maximum normal strain in the bar?

